



2018 COMFORT Collection



INTERNATIONAL
Intex Development Co., Ltd.
9th Floor, Everbright Centre,
108 Gloucester Road, Wanchai,
Hong Kong
Tel: (852) 2827-0000
Fax: (852) 2311-8200
E-mail: info@intexdevelopment.com
Web: www.intexdevelopment.com

USA
Intex Recreation Corp.
P.O. Box 1440
Long Beach, CA 90801-1440
USA
Tel: (310) 549-5400
Fax: (310) 513-6905
Web: www.intexcorp.com



EUROPE
Intex Trading B.V.
Venneveld 9,
4705 RR Roosendaal,
The Netherlands
Tel: (31) 165-593920
Fax: (31) 165-593969
E-mail: info@intexcorp.nl
Web: www.intexcorp.nl

Intex Trading s.r.o.
Benešovská 23
101 00 Praha 10
Czech Republic
Tel: (420) 267 312 645
Fax: (420) 267 312 552
E-mail: info@intexcorp.cz
Web: www.intexdevelopment.com

Unitex Service (France) S.A.S.
Z.A. de Milleure Bois du Ban - N°4
71480 LE MIROIR, France
Tel: (33) 385 75 64 64
Fax: (33) 385 75 64 65
E-mail: info@intexcorp.com.fr
Web: www.intex.fr



2018 COMFORT Collection



Intex Development Co. Ltd., Hong Kong



Intex Recreation Corp, Long Beach, CA, USA



Intex Trading B.V., The Netherlands



Unitex Service (France) S.A.S., France



Intex Administration Building Landscape, Xiamen, China

Intex Manufacturing and Distribution Complex, Xiamen, China

INTRODUCTION

2018

The Intex Family of companies is dedicated to developing and manufacturing the highest quality products that not only provide the best value in price, but are innovative, fun and exciting. Backed by excellent Customer Service, Intex also provides first-rate after sales support. The 100+ independently owned and locally operated companies that make up the Intex Family, all embrace this commitment to quality, service and price and are committed to working together to ensure the satisfaction of the families and individuals across the globe who enjoy these products. This has become the hallmark of Intex around the world.

As a true industry leader, Intex boasts state of the art factories, trained and motivated people, products that meet rigorous testing requirements, and a Customer Service organization that will go extra lengths to ensure our customers are satisfied and happy with their purchases.

When you purchase an Intex product you can be confident that you are buying the best product, at the best price, backed by the best Customer Service organization in the industry.

Intex is committed to delivering top quality products at a great value with the backing of a responsive Customer Service organization. Our Airbed line is unmatched for breadth and beauty. With the introduction of our new innovative, patented Fiber-Tech™ Technology, we have engineered a way to combine durability with exceptional comfort, creating airbeds that rival the stability, support and comfort of a traditional mattress. The “Dura-Beam®” series utilizes superior Fiber-Tech™ interior construction to create a line of airbeds that are lighter, stronger, and more comfortable than an average airbed. With “PremAire®”, Intex has combined our manufacturing technologies with our engineering strengths of Fiber-Tech™ to bring you the most innovative, luxurious, and comfortable bed in the market today.

Our Comfort Rest® line of airbeds consists of four series designed to meet all of your customers' needs: the “Dura-Beam® Standard Series” offers a line of durable and comfortable airbeds with attractive opening price points. “Dura-Beam® Plus Series” features a wide variety of luxurious premium quality raised airbeds. Each airbed has been engineered and tested to provide you with superior functionality that guarantees the ultimate sleeping experience. Our top-of-the-line “PremAire® Airbeds” bring a new level of luxury and innovation to our collection. Elegantly designed with puncture resistant laminated PVC exterior, plushy pillow top and superb structural durability, PremAire® Airbeds bring you and your guests unparalleled comfort. The “Multi-Use / Camping” series is engineered for camping, travel, and all-around rugged use, with beds perfectly suited to the outdoor environment. And for the young at heart, our “Air Furniture” series comes with bright colors and fresh design concepts, guaranteed to attract a loyal following of young adults! Ask your Intex representative for any of our product catalogs – we are confident that you will agree that Intex's product line is unmatched in meeting your needs.



Commitment to Excellence

Intex's Commitment to Excellence encompasses every single product that leaves our factory. We achieve this by maintaining the highest levels of quality assurance — such as inflating and testing every single airbed to ensure the Air Lock® guarantee. It's that simple.



100% of our products are quality tested to be air tight before they leave our factory.

In today's rapidly evolving and highly competitive environment, this translates into a total commitment to product quality, including conformity to all relevant safety & quality regulations and standards. Examples include:

- EN 16927, safety and test methods for mini pools (European standard)
- EN 16582, safety and test methods for domestic swimming pools other than mini pools (European standard)
- Regulation (EC) No.1907/2006 "Registration, Evaluation, Authorisation and Restriction of Chemicals (REACH)"
- EN 71 "Safety of toys" (European standard)
- EN 13138 "Buoyant aids for swimming instruction" (European standard)
- EN15649 "Floating leisure articles for use on and in the water" (European standard for air mats, lounges and other similar items)
- EN 60335-2-41 "Safety of household and similar electrical appliances, particular requirements for pumps" (European standard for water pumps)
- ISO 6185-1 "Inflatable boats" (International standard for Sports Boats)
- NMMA-ABYC (USA standard for hi-end sports boats)
- ASTM F963 "Standard Consumer Safety Specification for Toy Safety" (USA toy standard)
- ANSI/APSP-4 "AGP standard" (USA standard for above ground pools)
- CPSIA "Consumer Product Safety Improvement Act" (USA regulation of consumer and children's products)

- ASTM F2666 "Small pools standard" (USA standard for pools under 36" water depth)
- UL1450 "Electric inflators" (USA standard for electric inflators)
- UL1081 "Swimming pool pumps, filters and chlorinators" (USA standard)
- UL1563 "Electric Spas" (USA standard for Spa)

Intex's Commitment to Excellence extends to helping our environment and supporting the ecosystem. It begins with product design. Intex's filter pumps operate on much lower amps than most filter pumps in the market, reducing electricity consumption. Our saltwater systems clean pools using only natural salt, eliminating the ongoing need for environmentally unfriendly packaged chlorine.

Intex also operates one of the most comprehensive recycling programs in the industry. We are one of the earliest companies in China to successfully obtain a license to ship consumers' returns in the original package back to China to be recycled. Therefore, used materials and product returns are prevented from going to landfills and instead re-used in the manufacturing process where up to 10% of annually produced PVC is recycled.

Intex designs all of our own packaging for our products. We constantly challenge our methods of packaging to improve

efficiency and reduce waste. More compact packaging techniques save cardboard while cutting down on space utilization, saving freight and fuel consumption.

As a manufacturer, Intex knows it has a responsibility to manage the amount of waste produced. As an employer of over ten thousand people, we also encourage our own employees to recycle, reduce waste, and be conscious of the environment. Starting from recycling corners for all our worldwide office facilities, our Factory has worked with the local government as well as through sponsorships with key partners to strengthen our efforts to be more eco-friendly. Intex has worked to provide incentives and seminars to employees as well as setting targets to reduce energy consumption. In addition, Intex has made significant investment in technology to achieve these goals. For example, we have implemented a frequency converter system which converts diesel to natural gas, installed solar water heaters and set up a recycled sewage system, and invested in equipment that reduces gas emissions.

From product design, to more efficient processes that save energy and reduce waste, to a world class recycling program, to more energy efficient offices, the people at Intex are striving to provide the best value products anywhere while constantly keeping our global ecosystem in mind.



2018

08	Fiber-Tech™ Technology
10	Dura-Beam® Standard Series
16	Dura-Beam® Plus Series
32	PremAire® Airbeds
38	Multi-Use / Camping
48	Air Furniture
64	Accessories



100% of our products are
quality tested to be air tight
before they leave our factory.



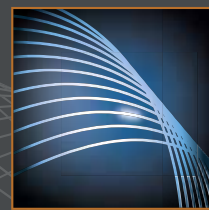

INTRODUCING
FIBER-TECH™ TECHNOLOGY
 by **INTEX®**

Designed for Comfort
 Engineered for Durability

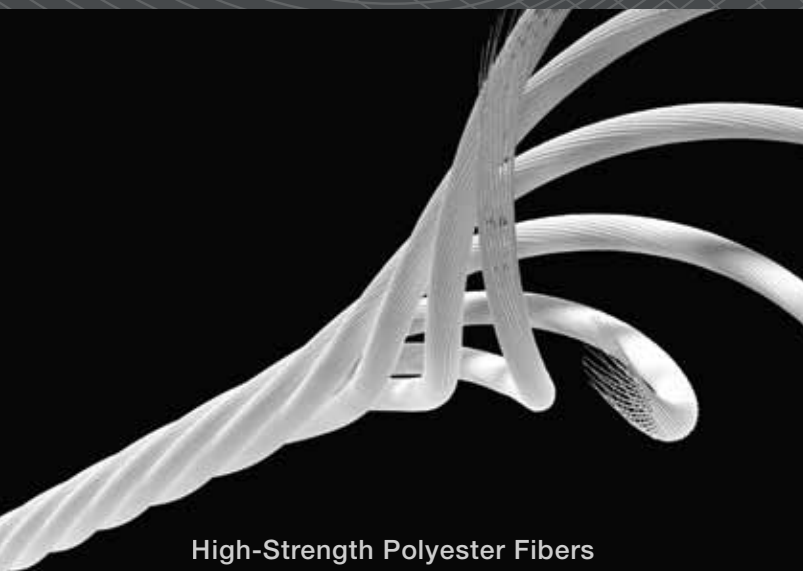

High-Strength Polyester Fibers



Fiber-Tech™ Interior Construction



I-Beam Interior Construction

An Incredible Night's Sleep Starts With a Single Thread...

CONTOURED SUPPORT SYSTEM

Our innovative, patented Fiber-Tech™ Technology airbeds are comprised of thousands of high-strength polyester fibers. Unlike traditional airbed construction, these high-strength polyester fibers do not stretch over time, resulting in amazing durability for years of lasting comfort. Fiber-Tech™ interior construction provides the ideal firmness for superb support and rejuvenating sleep.



FIBER-TECH™
 TECHNOLOGY

Standard interior construction has been enhanced with lightweight, high-strength fibers for amazing durability and comfort!

U.S. Patent No. 8,562,773 and U.S. Patent No. 9,156,203

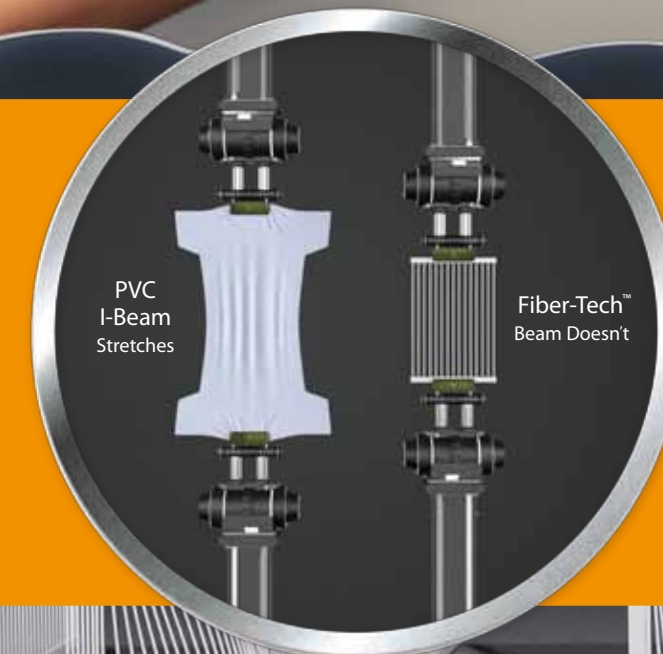

PVC I-Beam Stretches

Fiber-Tech™ Beam Doesn't

Great Sleep Made Simple

Our Dura-Beam® Standard airbeds with Fiber-Tech™ Technology are perfect for short-term usage while providing an affordable sleep solution to any indoor or outdoor occasion. The Dura-Beam® Standard airbeds feature Fiber-Tech™ interior construction with vertical beams with a bed height ranging from 10 inches to 20 inches high from the floor, making it easy to get in and out. This airbed is ideal for traveling, camping, and for accommodating overnight guests.

DURA-BEAM® STANDARD SERIES



DURABLE
INTERIOR CONSTRUCTION



PORTABLE



**QUICK INFLATION &
DEFLATION**

DURA-BEAM® STANDARD SERIES DELUXE SINGLE-HIGH AIRBED WITH FIBER-TECH™ TECHNOLOGY

NEW

Introducing 10" (25cm) Deluxe Single-High Airbed with Fiber-Tech™ Technology. The perfect all-around sleeping solution, this compact airbed provides both campers and in-home users with the convenience of a low-profile, light-weight, comfortable bed that is built for long-lasting durability.

This airbed is covered in a soft, flocked sleeping surface for enhanced comfort. Our patented Fiber-Tech™ interior construction provides superb support and structural stability for a restful night's sleep. Made for durability and comfort, anywhere you go.



AIRBED ONLY	Approximate Inflated Size	Case Pack	Case Weight
64101 / E Twin	39" x 75" x 10" 99cm x 1.91m x 25cm	4 ea	23.7 lb (10.8 kg)
64102 / E Full	54" x 75" x 10" 1.37m x 1.91m x 25cm	3 ea	23.5 lb (10.7 kg)
64103 / E Queen	60" x 80" x 10" 1.52m x 2.03m x 25cm	3 ea	27.2 lb (12.4 kg)

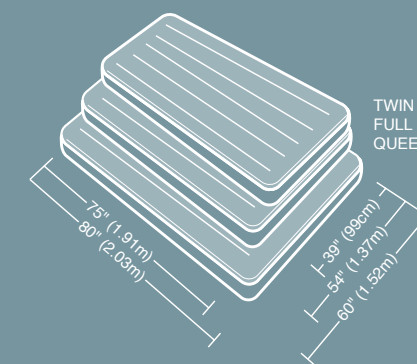

INDOOR / OUTDOOR MULTI-USE SINGLE-HIGH AIRBED

- Fiber-Tech™ Technology
- Quality tested flocked top with vinyl sides and bottom
- Strong and lightweight
- 2-in-1 valve



SHELF BOX



FOLDS COMPACTLY

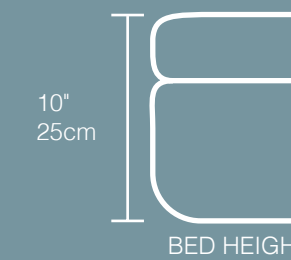

10"
25cm

BED HEIGHT

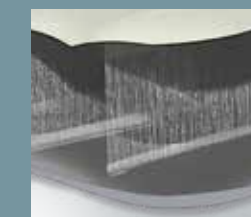

Fiber-Tech™ Technology

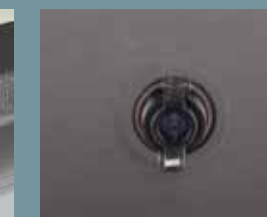

2-in-1 valve with extra-wide openings for fast inflating and deflating

DURA-BEAM® STANDARD SERIES

PILLOW REST MID-RISE AIRBED

WITH FIBER-TECH™ TECHNOLOGY

NEW

Introducing the new 12" Pillow Rest Mid-Rise Airbed with Fiber-Tech™ Technology. This compact airbed offers the perfect all-around sleeping solution, providing both campers and in-home users with the convenience of a lightweight, comfortable bed that is built for great sleep anywhere you go. This airbed is covered in a soft, velvety sleeping surface for extra comfort. The powerful built-in pump easily inflates and deflates the airbed within minutes. Whether for camping, vacation, or indoor use, this bed is the perfect multi-functional solution.



WITH BUILT-IN ELECTRIC PUMP		Approximate Inflated Size	Built-in Pump	Case Pack	Case Weight
64115E 64116	Twin	39" x 75" x 12" 99cm x 1.91m x 30cm	110 - 120V 220 - 240V	3 ea	30.1 lb (13.7 kg)
64117E 64118	Queen	60" x 80" x 12" 1.52m x 2.03m x 30cm	110 - 120V 220 - 240V	2 ea	28.9 lb (13.2 kg)

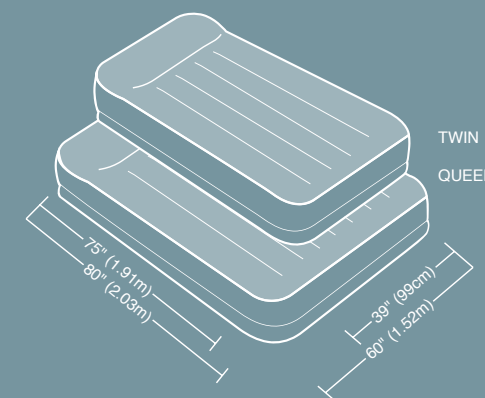

AC Electric Pump INFLATING TIMES*	
TWIN	1 ¼ Minutes
QUEEN	3 Minutes

*INFLATING TIME VARIES BY MATTRESS SIZE AND DESIRED FIRMNESS

ELEVATED FOR CONVENIENCE

- Fiber-Tech™ Technology
- Mattress is raised 12" (30cm) from the floor for convenience
- A built-in pillow provides bed-like comfort

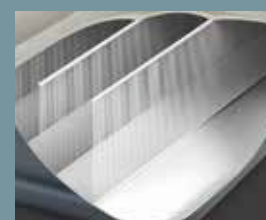
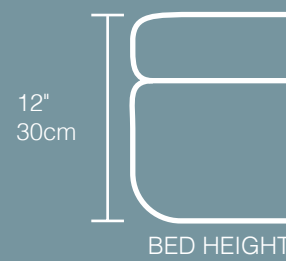

Fiber-Tech™ Technology



Built-in AC Electric Pump



Built-in pillow for added convenience

DURA-BEAM® STANDARD SERIES

PILLOW REST RAISED AIRBED

WITH FIBER-TECH™ TECHNOLOGY

Our best-selling Pillow Rest Raised Airbed has been enhanced with Fiber-Tech™ interior construction, providing you added comfort and durability, and an overall better sleeping experience.



WITH BUILT-IN ELECTRIC PUMP		Approximate Inflated Size	Built-in Pump	Case Pack	Case Weight
64121E 64122	Twin	39" x 75" x 16½" 99cm x 1.91m x 42cm	110 - 120V 220 - 240V	3 ea	33.6 lb (15.3 kg)
64123E 64124	Queen	60" x 80" x 16½" 1.52m x 2.03m x 42cm	110 - 120V 220 - 240V	2 ea	31.7 lb (14.4 kg)

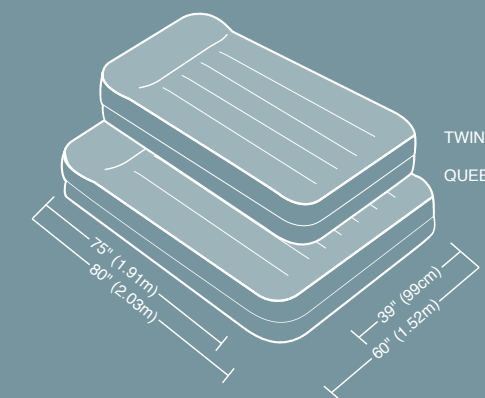

AC Electric Pump INFLATING TIMES*	
TWIN	2 Minutes
QUEEN	3 Minutes

*INFLATING TIME VARIES BY MATTRESS SIZE AND DESIRED FIRMNESS

ELEVATED FOR CONVENIENCE

- Fiber-Tech™ Technology
- Mattress is raised 16½" (42cm) from the floor for convenience
- A built-in pillow provides bed-like comfort

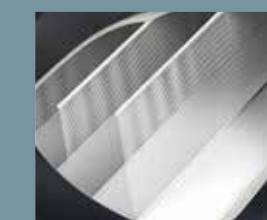
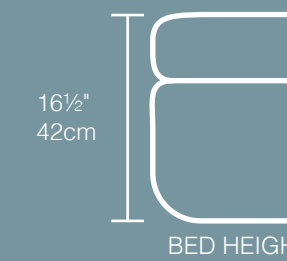

Fiber-Tech™ Technology



Built-in AC Electric Pump



Built-in pillow for added convenience

DURA-BEAM® STANDARD SERIES

DELUXE PILLOW REST RAISED AIRBED

WITH FIBER-TECH™ TECHNOLOGY

A deluxe version of our Pillow Rest Raised Airbed! Modified with Fiber-Tech™ interior construction, overnight guests will enjoy the added comfort, support and firmness this mattress brings. The outer perimeter frame on the sleeping surface provides added edge support – making the bed feel roomier and easier to get in and out of.



WITH BUILT-IN ELECTRIC PUMP	Approximate Inflated Size	Built-in Pump	Case Pack	Case Weight
64131E 64132	Twin 39" x 75" x 16½" 99cm x 1.91m x 42cm	110 - 120V 220 - 240V	3 ea	37.7 lb (17.1 kg)
64135E 64136	Queen 60" x 80" x 16½" 1.52m x 2.03m x 42cm	110 - 120V 220 - 240V	2 ea	34.5 lb (15.7 kg)

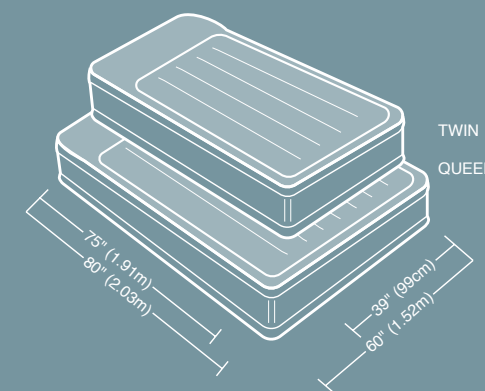

AC Electric Pump INFLATING TIMES*	
TWIN	2 Minutes
QUEEN	3 Minutes

*INFLATING TIME VARIES BY MATTRESS SIZE AND DESIRED FIRMNESS

BUILT-IN PILLOW AND SOFT FLOCKED TOP FOR COMFORT

- Fiber-Tech™ Technology
- Mattress is raised 16½" (42cm) from the floor for convenience
- Indented sides positioned perfectly to keep fitted sheets firmly in place

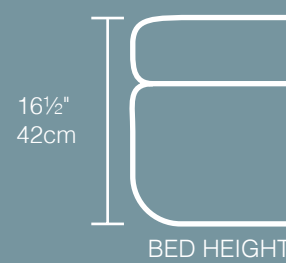
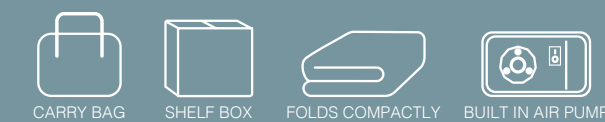

Deluxe Pillow Rest Construction



Built-in AC Electric Pump



Built-in pillow for added convenience

DURA-BEAM® STANDARD SERIES

ESSENTIAL REST AIRBED

WITH FIBER-TECH™ TECHNOLOGY

Our Essential Rest Airbed with Fiber-Tech™ interior construction features a traditional bed height so guests will feel right at home. Your houseguests will love the better support and firmness Fiber-Tech™ Technology brings. The indented sides help grip fitted sheets. The outer perimeter frame on both top and bottom provides additional stability and support. This full-featured bed is all you need for a great night's sleep.



WITH BUILT-IN ELECTRIC PUMP	Approximate Inflated Size	Built-in Pump	Case Pack	Case Weight
64139E 64140	Queen 60" x 80" x 20" 1.52m x 2.03m x 51cm	110 - 120V 220 - 240V	2 ea	36.5 lb (16.6 kg)

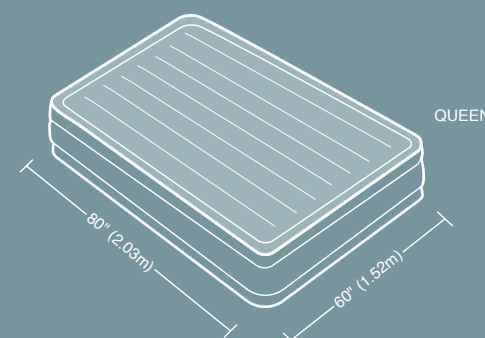

AC Electric Pump INFLATING TIMES*	
QUEEN	3½ Minutes

*INFLATING TIME VARIES BY MATTRESS SIZE AND DESIRED FIRMNESS

ELEVATED FOR COMFORT & CONVENIENCE

- Fiber-Tech™ Technology
- The Dual-chamber construction provides ample vertical stability
- Mattress is raised 20" (51cm) from the floor for convenience
- Cozy flocked mattress top

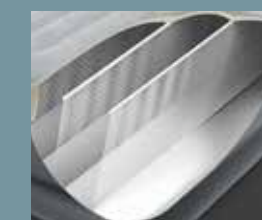
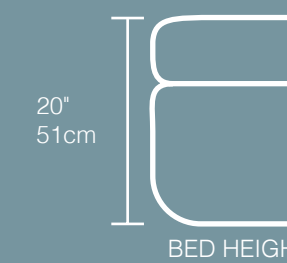
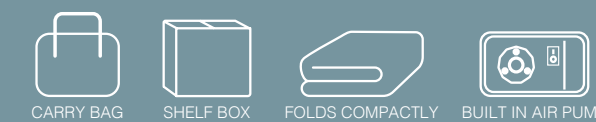

Fiber-Tech™ Technology



Built-in AC Electric Pump

The sleep you've always dreamed of isn't a dream at all



Our Dura-Beam® Plus airbeds with Fiber-Tech™ Technology are the perfect sleep solution for overnight guests to ensure sweet dreams. This premium line features Fiber-Tech™ interior construction for superb structural stability and support, with enhanced sleeping surfaces – fleece top, pillow top, or foam top. Dura-Beam® Plus airbeds are designed with a taller bed height ranging from 13 inches to 22 inches from the floor. For added convenience, the powerful built-in pump easily inflates and deflates the airbed within minutes. This full-featured bed is all you need for a great night's sleep.

DURA-BEAM® PLUS SERIES



DURABLE
INTERIOR CONSTRUCTION



COMFORTABLE SURFACE



BUILT-IN ELECTRIC PUMP
WITH HAND PUMP OPTION



HIGH RISE
FOR REAL BEDLIKE EXPERIENCE



Dura-Beam® Airbed

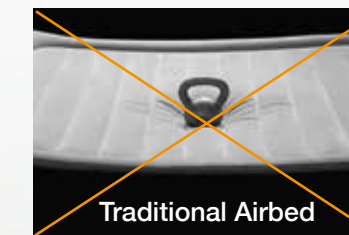

Traditional Airbed

COMFORT-PLUSH AIRBED

WITH FIBER-TECH™ TECHNOLOGY

Our most popular bed in the Dura-Beam® series with three different bed heights to choose from, our Comfort-Plush Airbeds offer the perfect combination of luxurious comfort and convenience.



COMFORT-PLUSH HORIZONTAL BEAM AIRBED

- Fiber-Tech™ Technology
- Quality tested flocked top and sides with vinyl bottom

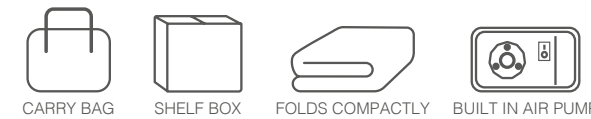
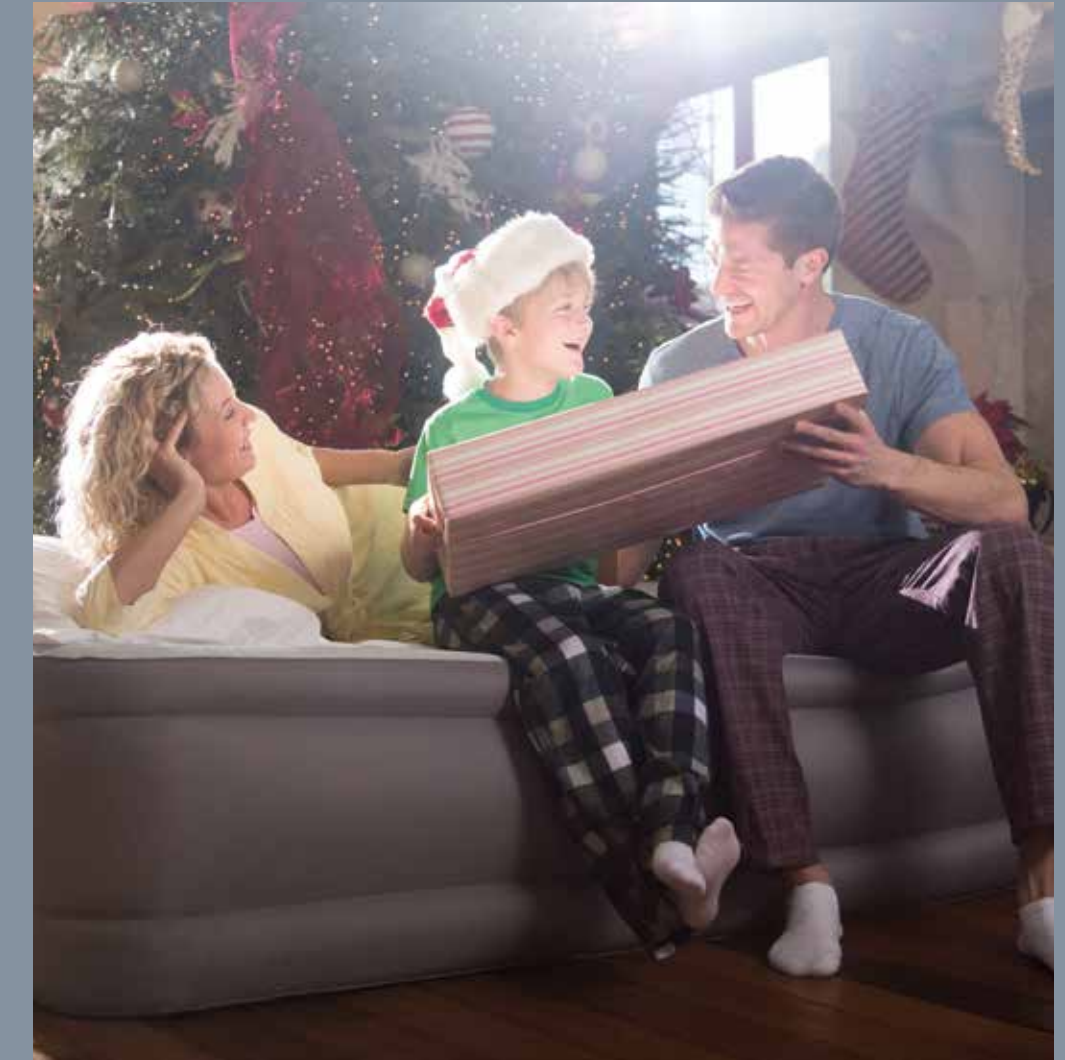
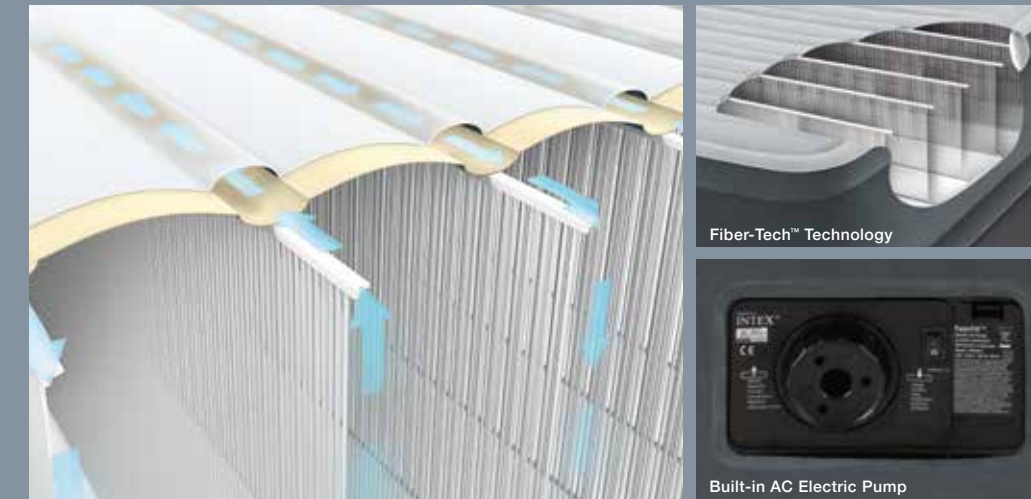
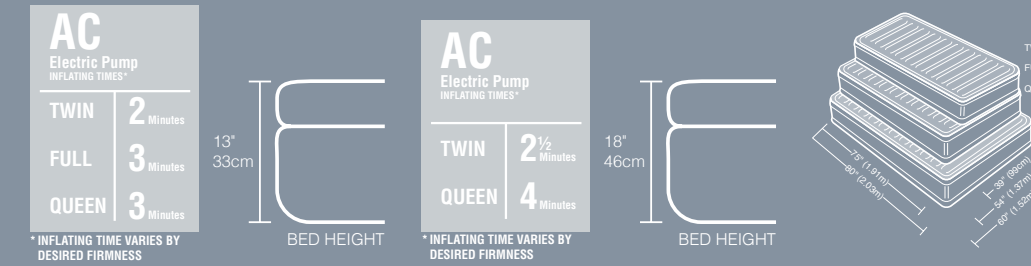

WITH BUILT-IN ELECTRIC PUMP		Approximate Inflated Size	Built-in Pump	Case Pack	Case Weight
67765E	Twin	39" x 75" x 13" 99cm x 1.91m x 33cm	110 - 120V 220 - 240V	3 ea	39.8 lb (18.1 kg)
67766E	Full	54" x 75" x 13" 1.37m x 1.91m x 33cm	110 - 120V 220 - 240V	2 ea	32.4 lb (14.7 kg)
67769E	Queen	60" x 80" x 13" 1.52m x 2.03m x 33cm	110 - 120V 220 - 240V	2 ea	36.7 lb (16.7 kg)

WITH BUILT-IN ELECTRIC PUMP		Approximate Inflated Size	Built-in Pump	Case Pack	Case Weight
64411E	Twin	39" x 75" x 18" 99cm x 1.91m x 46cm	110 - 120V 220 - 240V	3 ea	45.2 lb (20.5 kg)
64412E	Queen	60" x 80" x 18" 1.52m x 2.03m x 46cm	110 - 120V 220 - 240V	2 ea	40.9 lb (18.6 kg)

COMFORT-PLUSH AIRBED

WITH FIBER-TECH™ TECHNOLOGY

Each bed is covered in plush flocking that is soft to the touch, and the horizontal air chambers provide added stability and support around the entire bed. For extra convenience, this bed comes with a powerful built-in electric pump for fast inflation and deflation.



COMFORT-PLUSH HORIZONTAL BEAM AIRBED

- Fiber-Tech™ Technology
- Quality tested flocked top and sides with vinyl bottom

AC
Electric Pump
INFLATING TIMES*

QUEEN | 4 ½
Minutes

* INFLATING TIME VARIES BY DESIRED FIRMNESS

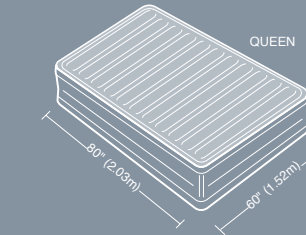
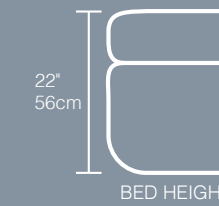

WITH BUILT-IN ELECTRIC PUMP		Approximate Inflated Size	Built-in Pump	Case Pack	Case Weight
64417E	Queen	60" x 80" x 22"	110 - 120V	2 ea	46.7 lb (21.2 kg)
64418		1.52m x 2.03m x 56cm	220 - 240V		

ULTRA PLUSH AIRBED

WITH FIBER-TECH™ TECHNOLOGY

Here's an airbed that is sure to impress your most important guests: The Ultra Plush Airbed is designed with revolutionary Fiber-Tech™ Technology. This raised bed combines comfort, convenience, and great appearance into one luxurious airbed, with its unique textured sleeping surface and inflated outer perimeter band for superior stability, comfort and support.



ELEVATED WITH BUILT-IN ELECTRIC PUMP

- Fiber-Tech™ Technology
- Textured pillow top for added comfort
- 18" (46cm) Raised height
- Built-in pump for rapid inflation and deflation

AC Electric Pump INFLATING TIMES*	
TWIN	2 Minutes
QUEEN	3 ½ Minutes

*INFLATING TIME VARIES BY DESIRED FIRMNESS

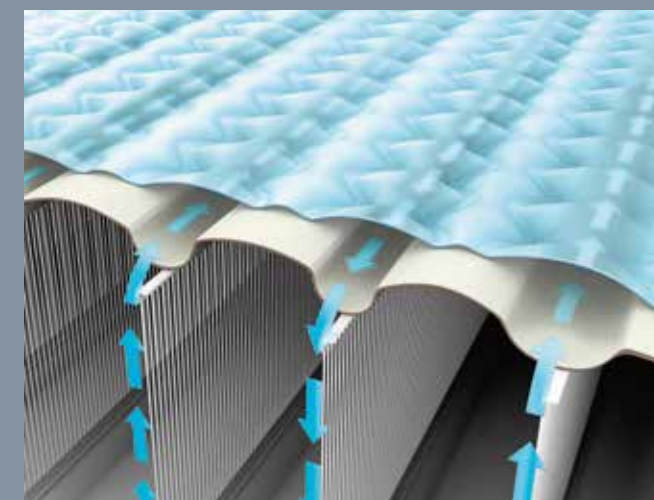
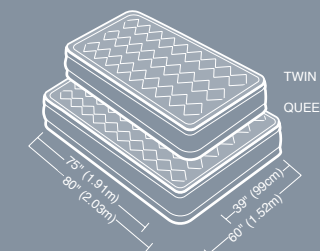
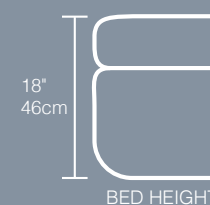

WITH BUILT-IN ELECTRIC PUMP		Approximate Inflated Size	Built-in Pump	Case Pack	Case Weight
64455E 64456	Twin	39" x 75" x 18" 99cm x 1.91m x 46cm	110 - 120V 220 - 240V	2 ea	29.3 lb (13.3 kg)
64457E 64458	Queen	60" x 80" x 18" 1.52m x 2.03m x 46cm	110 - 120V 220 - 240V	2 ea	40.3 lb (18.3 kg)

U.S. Patent No. 6,568,011

PRIME COMFORT ELEVATED AIRBED

WITH FIBER-TECH™ TECHNOLOGY

Introducing our 20" Prime Comfort Elevated Airbed with Fiber-Tech™ Technology, the perfect all around sleeping solution with an enhanced soft, fleece flocked top. The double layered construction allows you to tuck in standard size queen bed sheets easily and securely. Our patented Fiber-Tech™ interior construction provides superb support and structural stability for restful night sleep. For added convenience the powerful built-in pump easily inflates and deflates the airbed within minutes.



ELEVATED WITH BUILT-IN ELECTRIC PUMP

- Fiber-Tech™ Technology
- 20" (51cm) Raised height
- Double Layered construction

AC Electric Pump INFLATING TIMES*	
TWIN	2 Minutes
QUEEN	3 ½ Minutes

*INFLATING TIME VARIES BY DESIRED FIRMNESS

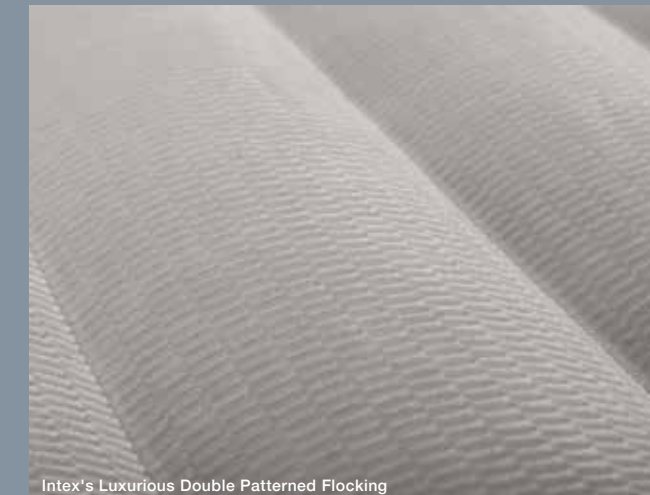
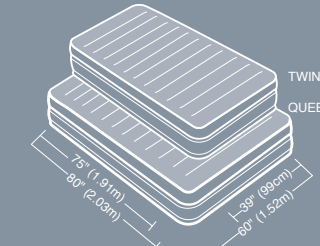
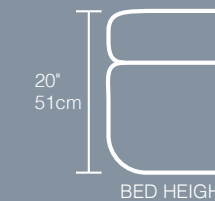

Intex's Luxurious Double Patterned Flocking

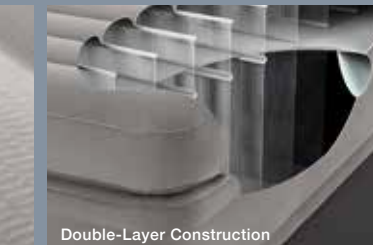

Double-Layer Construction



Built-in AC Electric Pump

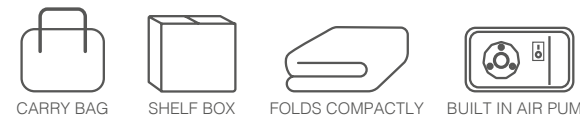
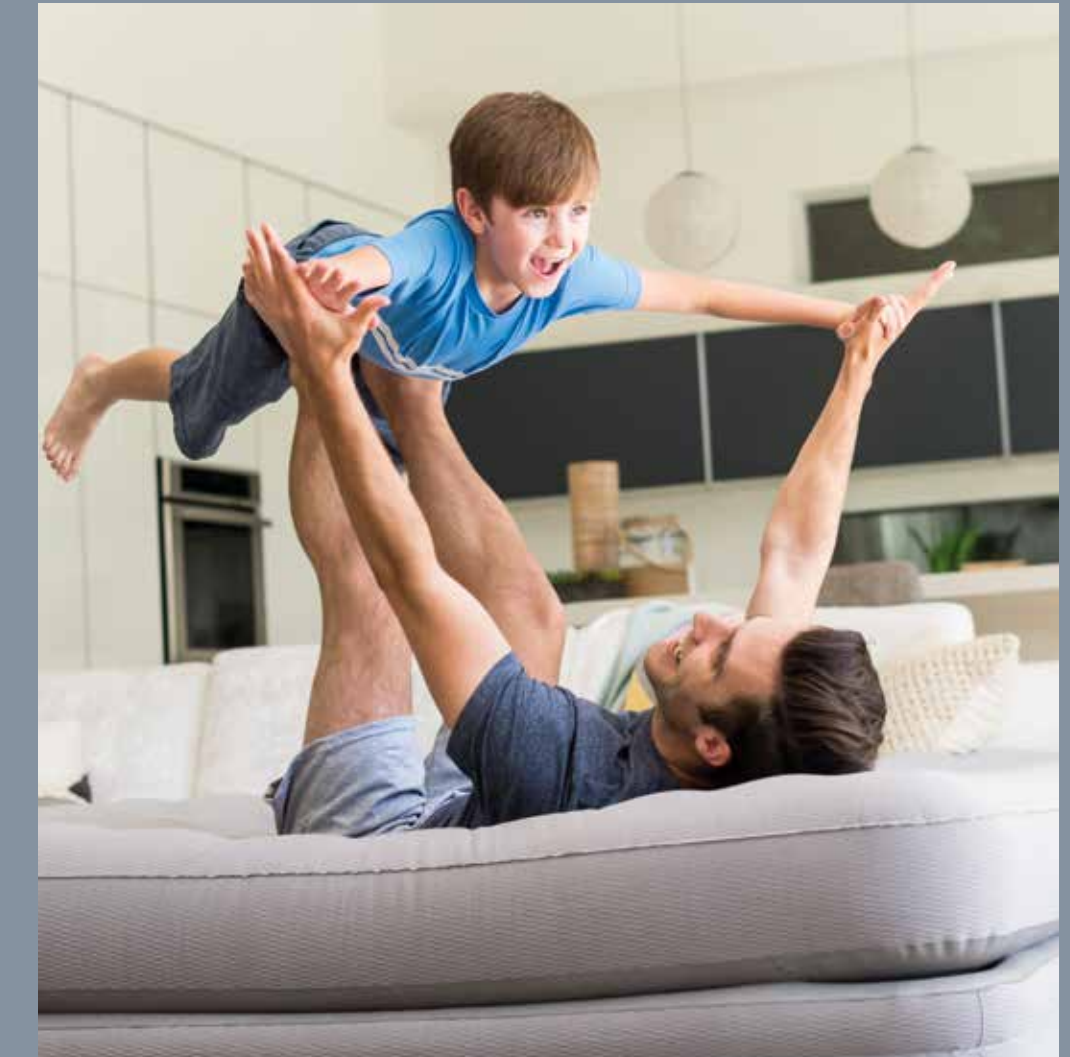

WITH BUILT-IN ELECTRIC PUMP		Approximate Inflated Size	Built-in Pump	Case Pack	Case Weight
64443E	Twin	39" x 75" x 20" 99cm x 1.91m x 51cm	110 - 120V 220 - 240V	2 ea	36.5 lb (16.6 kg)
64444					
64445E	Queen	60" x 80" x 20" 1.52m x 2.03m x 51cm	110 - 120V 220 - 240V	1 ea	25.3 lb (11.5 kg)
64446					

SUPREME AIR-FLOW™ AIRBED

WITH FIBER-TECH™ TECHNOLOGY

Our Supreme Air-Flow™ Airbed is engineered to provide the ultimate in comfort with the look and feel of a real high end bed. A network of inter-connected air pockets on the top and sides of the bed cause the air to flow smoothly and gradually across the sleeping surface for unbelievable comfort and stability. Constructed with innovative Fiber-Tech™ Technology, this mattress is firmer and more durable than ever before. The dual chamber construction provides firm support and allows for fitted sheets to tuck in easily. Topped with super soft Veletaire™ flocking this bed rivals any traditional mattress in comfort and stability.



ELEVATED WITH BUILT-IN ELECTRIC PUMP

- Fiber-Tech™ Technology
- 20" (51cm) Raised height
- Plush Velvetaire™ pillow top mattress surface
- Inflated bed fits standard sheets
- Network of inter-connected air pockets that allow air to flow smoothly and gradually across the top and side surfaces

AC Electric Pump INFLATING TIMES*	
TWIN	2 ½ Minutes
QUEEN	4 Minutes

*INFLATING TIME VARIES BY DESIRED FIRMNESS

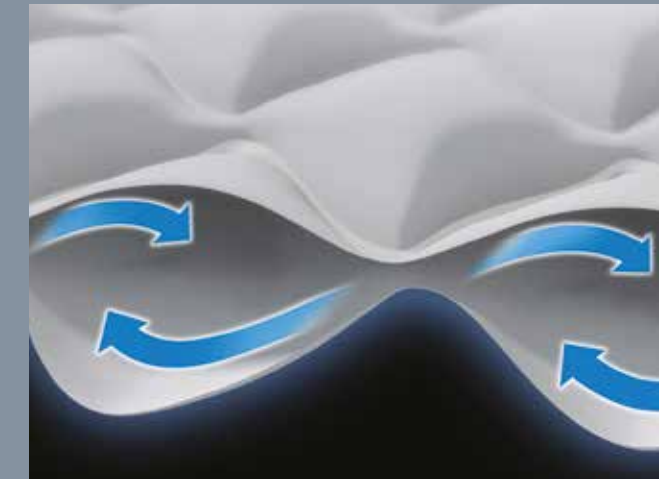
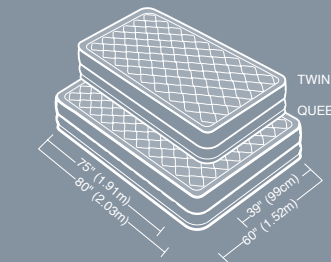
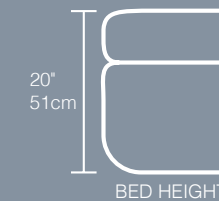

Double-Layer Beam Construction
U.S. Patent No. 7,636,970



Built-in AC Electric Pump



WITH BUILT-IN ELECTRIC PUMP		Approximate Inflated Size	Built-in Pump	Case Pack	Case Weight
64461E	Twin	39" x 75" x 20"	110 - 120V	1 ea	26.0 lb (11.8 kg)
64462		99cm x 1.91m x 51cm	220 - 240V		
64463E	Queen	60" x 80" x 20"	110 - 120V	1 ea	36.2 lb (16.5 kg)
64464		1.52m x 2.03m x 51cm	220 - 240V		

U.S. Patent No. 7,591,036 and U.S. Patent No. 7,406,735

FOAM TOP AIRBED

WITH FIBER-TECH™ TECHNOLOGY

Guests will enjoy a luxurious night's sleep with the cozy Foam Top High-Rise Airbed. The soft Plush Velvetaire™ flocking surface and foam top layer comfortably contours the body for a rejuvenating sleeping experience.

Made with the innovative Fiber-Tech™ Technology, this mattress is firmer and more durable than ever before. Raised edges provide stability and added support while the indented sides ensure your standard queen fitted sheets tuck in easily and securely.



ELEVATED WITH BUILT-IN ELECTRIC PUMP

- Fiber-Tech™ Technology
- Foam Top Layer
- 20" (51cm) Raised height
- Plush Velvetaire™ Flocked mattress surface

AC
Electric Pump
INFLATING TIMES*

QUEEN 3 1/2 Minutes

*INFLATING TIME VARIES BY DESIRED FIRMNESS

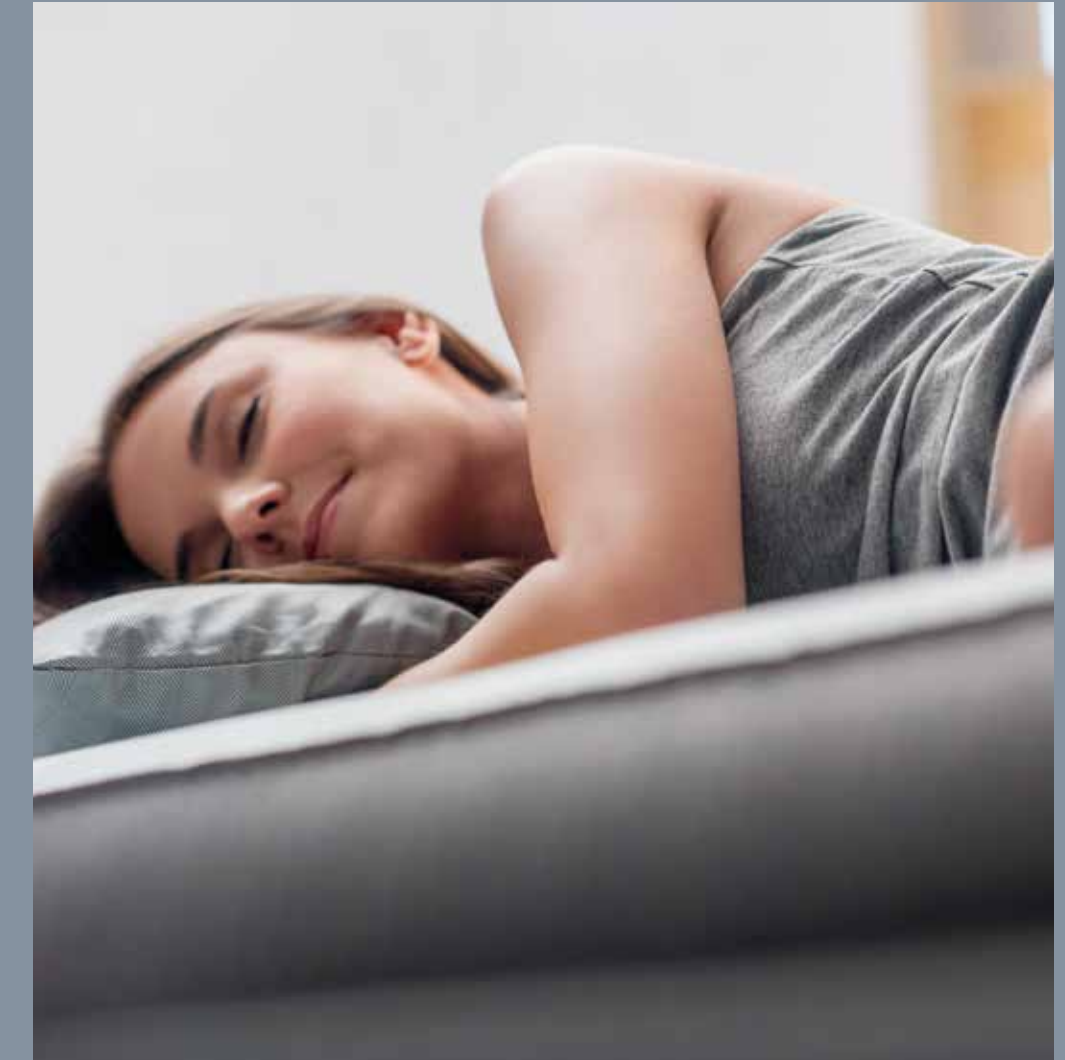
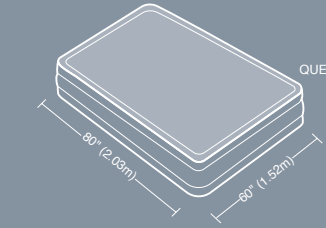
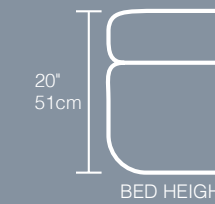

NEW

WITH BUILT-IN ELECTRIC PUMP		Approximate Inflated Size	Built-in Pump	Case Pack	Case Weight
64469E	Queen	60" x 80" x 20"	110 - 120V	1 ea	25.3 lb (11.5 kg)
64470		1.52m x 2.03m x 51cm	220 - 240V		

ULTRA PLUSH HEADBOARD AIRBED

WITH FIBER-TECH™ TECHNOLOGY

Get a quality night's sleep with the new Dura-Beam® Series Headboard Bed. The built-in headboard is versatile. It can be used as an ideal back support when lounging or watching T.V. and as a pillow stopper when sleeping, keeping your pillows from falling on the floor. The pillow top surface gives a cushioned feel for maximum comfort.



ELEVATED WITH BUILT-IN ELECTRIC PUMP

- Fiber-Tech™ interior construction
- Headboard keeps your pillows from falling off the bed throughout the night, and provides support when sitting up
- 18" (46cm) height provides easier access onto and off of the bed
- Vinyl puncture resistant sides add durability
- Pillow top surface delivers exceptional comfort

AC
Electric Pump
INFLATING TIMES*

QUEEN 4 ½
Minutes

*INFLATING TIME VARIES BY DESIRED FIRMNESS

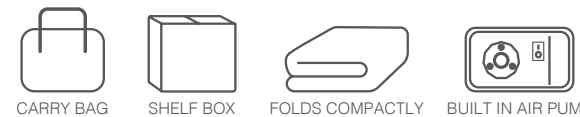
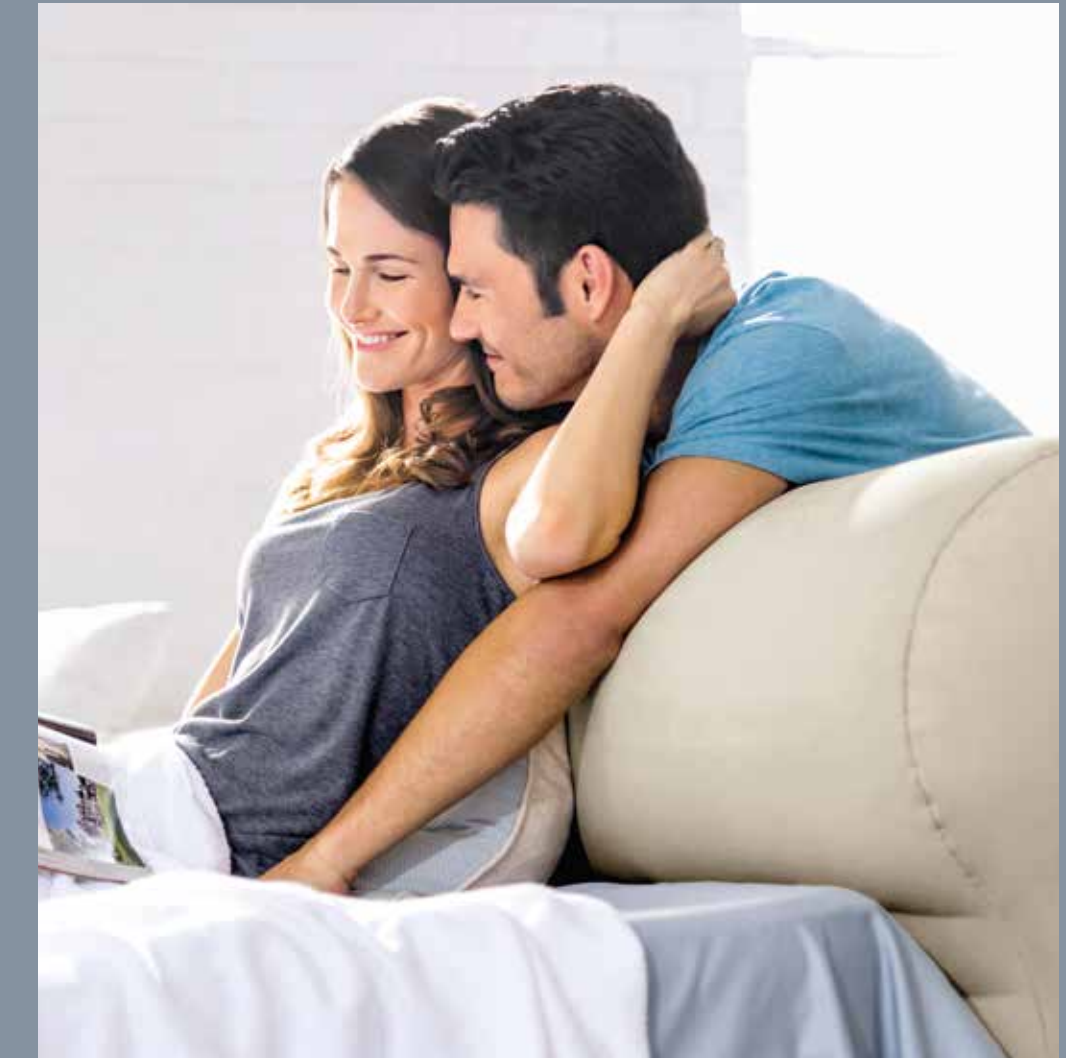
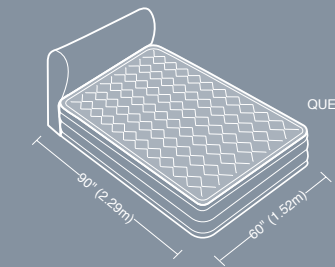
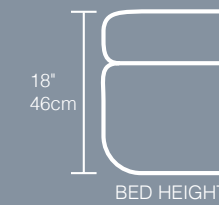

WITH BUILT-IN ELECTRIC PUMP		Approximate Inflated Size	Built-in Pump	Case Pack	Case Weight
64459E	Queen	60" x 90" x 31"	110 - 120V	1 ea	24.9 lb (11.3 kg)
64460		1.52m x 2.29m x 79cm	220 - 240V		

U.S. Patent No. 6,568,011

LUXURY REDEFINED

PremAire®

Elevated Series
with Fiber-Tech™ Technology

Our luxurious, innovative PremAire® line is expanded with exciting new additions.

All PremAire® airbeds are built with our patented and award winning Fiber-Tech™ Technology, offering superb structural stability and support. The high strength fibers provide an interior with amazing durability and unmatched comfort. Each PremAire® mattress is covered in a pillow top that ensures true comfort and promises a great night's sleep. The laminated PVC exterior provides a high quality puncture resistant surface that offers unrivaled resilience and durability.

The bed's elevated height makes it easier to get in and out of each morning. For extra convenience, this bed comes with a powerful built-in electric pump for fast inflation and deflation. Our revolutionary PremAire® mattress offers the perfect combination of luxurious comfort and best-in-class durability.



INTEX®

PremAire®

AIRBED WITH FIBER-TECH™ TECHNOLOGY

THE MOST ADVANCED AIRBED TECHNOLOGY

Luxurious flocked pillow top with heavy duty 2-ply laminated side walls and bottom



100% QUALITY TESTED

100% of our airbeds are quality tested to be air tight before they leave our factory

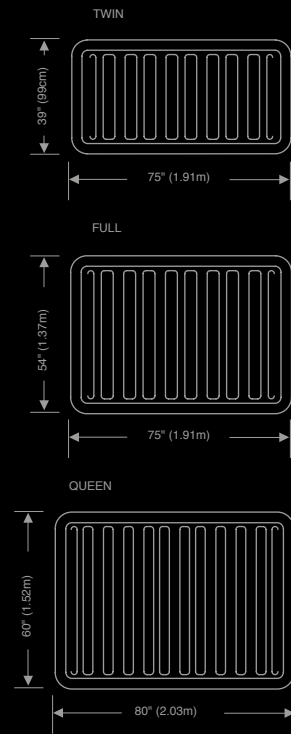

Built-in AC Electric Pump

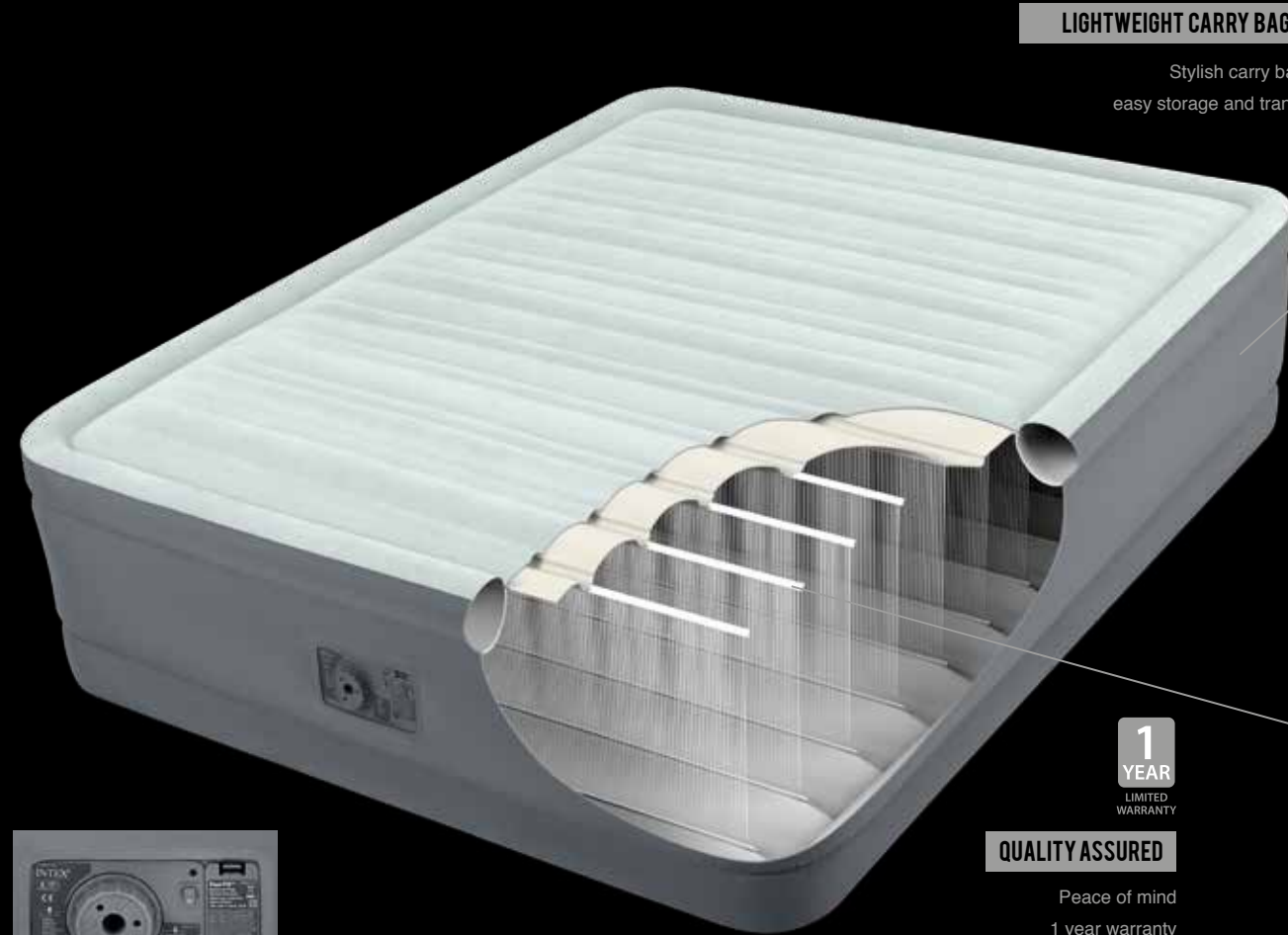

LIGHTWEIGHT CARRY BAG

Stylish carry bag for easy storage and transport

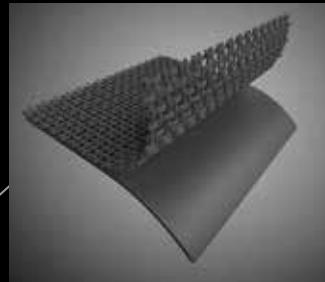

HEAVY DUTY 2-PLY MATERIAL

The 2-ply laminated side walls and bottom firmly retain air while providing a high quality puncture-resistant surface

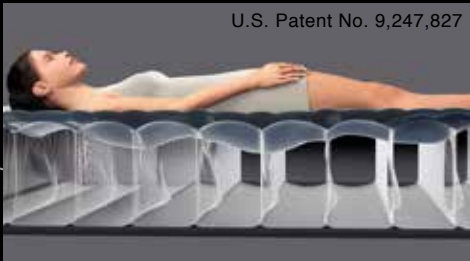

U.S. Patent No. 9,247,827

REVOLUTIONARY FIBER-TECH™ TECHNOLOGY

Revolutionary, patented Fiber-Tech™ support system provides the perfect combination of superb structural stability and support

1 YEAR LIMITED WARRANTY

QUALITY ASSURED

Peace of mind 1 year warranty

18in Bed Height

INFLATING TIMES*

AC Electric Pump

Twin	2½ minutes
Full	3½ minutes
Queen	4 minutes

* Inflating time varies by mattress size and desired firmness

Item	Size	Approximate Inflated Size	Built-in Pump	Case Pack	Case Weight
NEW 64901E 64902	Twin	39" x 75" x 18" 99cm x 1.91m x 46cm	110-120V 220-240V	2 ea	29.6 lb (13.5 kg)
NEW 64903E 64904	Full	54" x 75" x 18" 1.37m x 1.91m x 46cm	110-120V 220-240V	2 ea	35.7 lb (16.2 kg)
NEW 64905E 64906	Queen	60" x 80" x 18" 1.52m x 2.03m x 46cm	110-120V 220-240V	2 ea	40.0 lb (18.2 kg)

THE MOST ADVANCED AIRBED TECHNOLOGY

Luxurious waterproof flocked pillow top with heavy duty 2-ply laminated side walls and bottom

U.S. Patent No. 9,247,827

INFLATING TIMES*

AC Electric Pump

Queen	4½ minutes
-------	------------

* Inflating time varies by mattress size and desired firmness

18in Bed Height

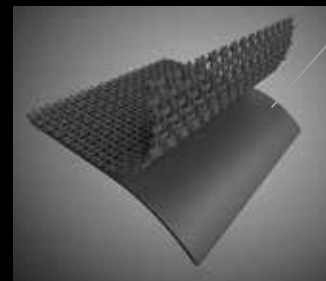

HEAVY DUTY 2-PLY MATERIAL

The 2-ply fully laminated airbed firmly retains air while providing a perfect combination of superior durability, firmness, and comfort

1 YEAR LIMITED WARRANTY

QUALITY ASSURED

Peace of mind 1 year warranty



100% QUALITY TESTED

100% of our airbeds are quality tested to be air tight before they leave our factory

Item	Size	Approximate Inflated Size	Built-in Pump	Case Pack	Case Weight
NEW 64925E 64926	Queen	60" x 80" x 18" 1.52m x 2.03m x 46cm	110-120V 220-240V	2 ea	45.2 lb (20.5 kg)



LIGHTWEIGHT CARRY BAG

Stylish carry bag for easy storage and transport



REVOLUTIONARY FIBER-TECH™ TECHNOLOGY

Revolutionary, patented Fiber-Tech™ support system provides the perfect combination of superb structural stability and support



AIRETOUCH™ CONTROL PANEL

Newly designed pump panel with firmness control dial and USB port (Patent pending)



BUILT-IN STORAGE WITH 2-IN-1 VALVE

Convenient storage for cord and small personal items. 2-in-1 Valve included for easy inflation and deflation with manual pump. Ideal for outdoor use.

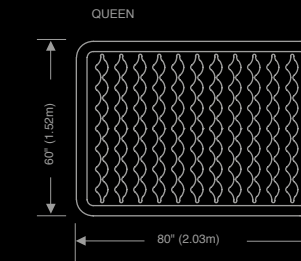

THE MOST INNOVATIVE AIRBED TECHNOLOGY

Six sided heavy duty 2-ply all laminated Dream Support Airbed



REVOLUTIONARY FIBER-TECH™ TECHNOLOGY

Revolutionary, patented Fiber-Tech™ support system provides the perfect combination of superb structural stability and support

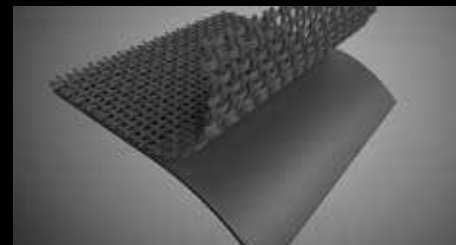

HEAVY DUTY 2-PLY MATERIAL

The 2-ply fully laminated airbed firmly retains air while providing a perfect combination of superior durability, firmness, and comfort



BUILT-IN STORAGE WITH 2-IN-1 VALVE

Convenient storage for cord and small personal items. 2-in-1 Valve included for easy inflation and deflation with manual pump. Ideal for outdoor use.

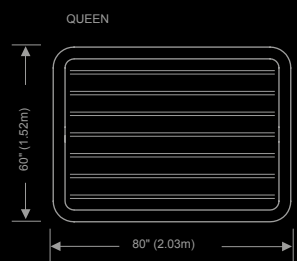
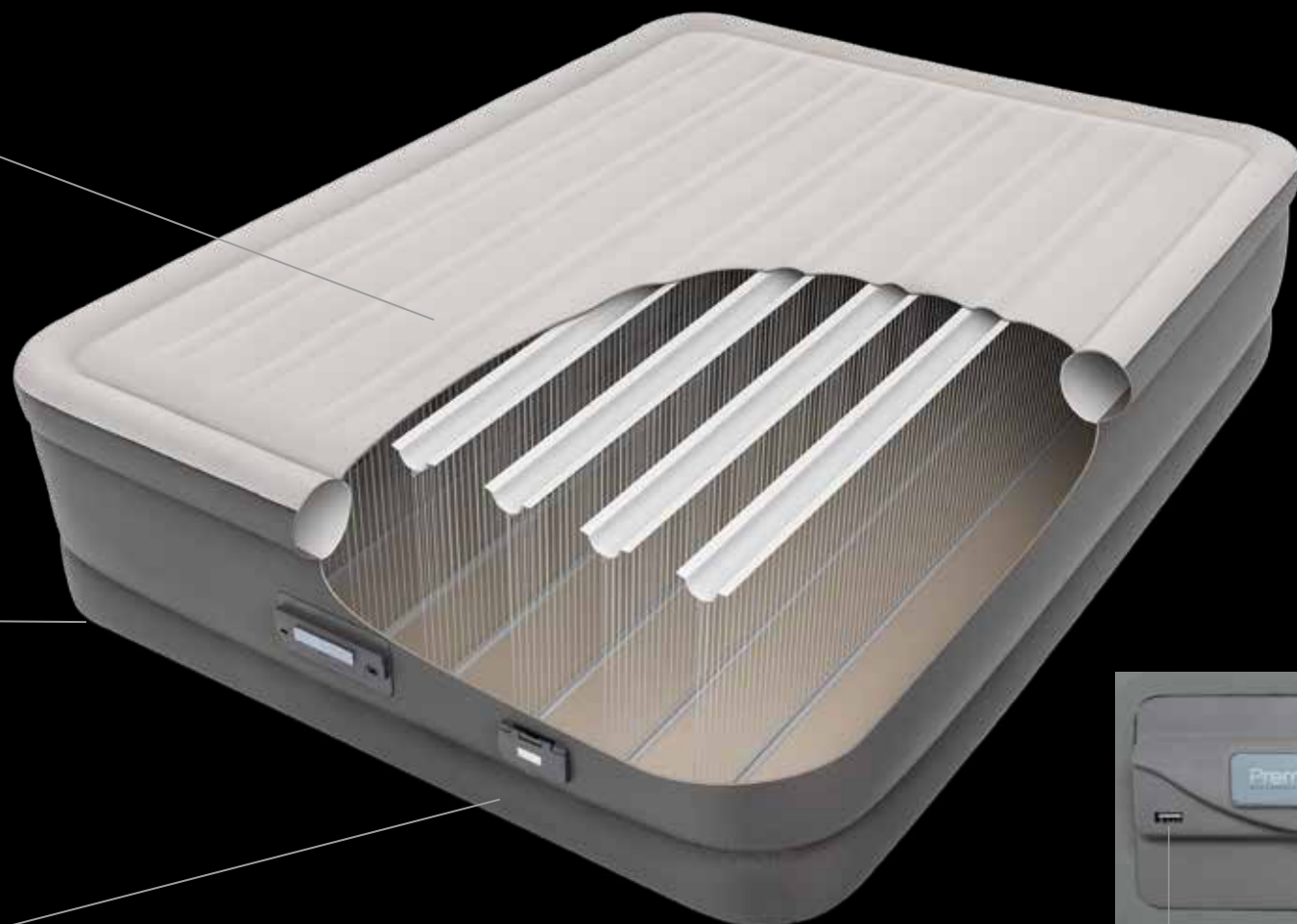

100% QUALITY TESTED

100% of our airbeds are quality tested to be air tight before they leave our factory

LIGHTWEIGHT CARRY BAG

Stylish carry bag for easy storage and transport



QUALITY ASSURED

Peace of mind
 1 year warranty



Auto inflate and deflate button



USB connection for charging



Firmness control button

AIRETOUCH™ CONTROL PANEL

Newly designed pump panel with firmness control dial and USB port (Patent pending)



18in
 Bed Height

INFLATING TIMES*

AC Electric Pump

Queen 4½ minutes

* Inflating time varies by mattress size and desired firmness

Item	Size	Approximate Inflated Size	Built-in Pump	Case Pack	Case Weight
64769E	Queen	60" x 80" x 18"	110-120V	1 ea	20.0 lb (9.1 kg)
64770		1.52m x 2.03m x 46cm	220-240V		



MULTI-USE

Enjoy the Great Outdoors

Intex knows that disconnecting from the pace of modern life doesn't mean giving up comfort. Intex Camping Airbeds have all been specifically designed to provide an uncompromising level of style, durability, comfort, and ease. Intex Camping Airbeds come in a variety of shapes, sizes, and styles to suit nearly any outdoor adventure.

DOWNY AIRBED

This airbed has a flocked top that provides a more comfortable sleeping surface. Its unique wave beam construction eliminates uncomfortable surface bumps and provides a flat, uniform sleeping surface. The Downy airbed can be inflated with either the built-in manual foot pump or a regular pump.



WITH BUILT IN FOOT PUMP		Approximate Inflated Size	Case Pack	Case Weight
66950 / E	Cot Size	30" x 75" x 8 3/4" 76cm x 1.91m x 22cm	6 ea	36.4 lb (16.6 kg)
66927 / E	Twin	39" x 75" x 8 3/4" 99cm x 1.91m x 22cm	4 ea	29.8 lb (13.5 kg)
66928 / E	Full	54" x 75" x 8 3/4" 1.37m x 1.91m x 22cm	3 ea	28.3 lb (12.9 kg)
66929 / E	Queen	60" x 80" x 8 3/4" 1.52m x 2.03m x 22cm	3 ea	32.3 lb (14.7 kg)

BUILT-IN FOOT PUMP FOR CONVENIENCE

- Unique built-in bellow foot pump for convenience—no separate pump needed. Just step down to inflate and the pump springs back automatically for the next cycle
- New and improved foot pump construction allows for faster inflation
- 2-in-1 valve for inflating with optional electric or manual pumps
- Conventional mattress sizes (L x W) for more sleeping area and a better fit for sheets
- 8 3/4" (22cm) mattress thickness for extra soft comfort



SHELF BOX FOLDS COMPACTLY



Wave Beam Construction



Built-in lightweight foot pump for easy inflation – No separate pump or power supply needed!

INFLATING TIMES*	
COT SIZE	2 Minutes
TWIN	3 Minutes
FULL	3 Minutes
QUEEN	4 Minutes

* INFLATING TIME VARIES BY MATTRESS SIZE AND DESIRED FIRMNESS

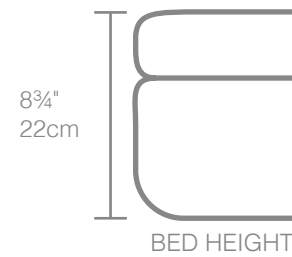

BED HEIGHT

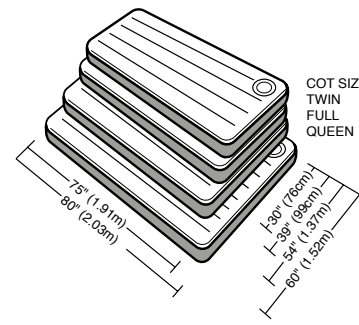

PRESTIGE DOWNY AIRBED

The perfect choice for the rugged outdoors. The flocked top provides a comfortable sleeping surface, and is easy to clean. The powerful battery-operated (6 x C-cell) pump goes anywhere!



WITH HANDHELD 6 C-CELL BATTERY PUMP		Approximate Inflated Size	Case Pack	Case Weight
66967 / E	Twin	39" x 75" x 8 3/4" 99cm x 1.91m x 22cm	4 ea	30.4 lb (13.8 kg)
66968 / E	Full	54" x 75" x 8 3/4" 1.37m x 1.91m x 22cm	3 ea	29.0 lb (13.2 kg)
66969 / E	Queen	60" x 80" x 8 3/4" 1.52m x 2.03m x 22cm	3 ea	33.4 lb (15.2 kg)

WITH HAND-HELD BATTERY PUMP

- 3-in-1 valve has extra-wide openings for fast inflating and deflating
- Conventional mattress sizes (L x W) for more sleeping area and a better fit for sheets
- Battery pump can also be used on other inflatables
- 8 3/4" (22cm) mattress thickness for extra soft comfort

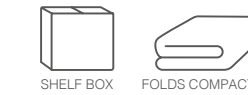

SHELF BOX FOLDS COMPACTLY

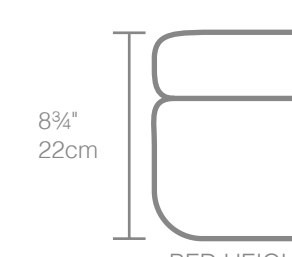
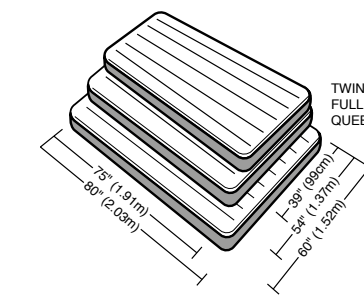

BED HEIGHT

INFLATING TIMES*	
TWIN	2 Minutes
FULL	2 Minutes
QUEEN	2 1/2 Minutes

* INFLATING TIME VARIES BY MATTRESS SIZE AND DESIRED FIRMNESS



Wave Beam Construction



For home or camping Operates on 6 C-cell batteries (not included)



The perfect camping companion

CLASSIC DOWNY AIRBED

You can't go wrong with this bed! Take it camping or use it for out of town guests. Our best selling Classic Downy Airbed is versatile and perfect for both in-home and camping. The wave beam construction creates a uniform sleeping surface that is guaranteed to give you a good night's rest wherever you are. Plush flocking provides a luxurious sleeping surface while keeping sheets in place. It's also easy to clean and waterproofed for camping use. The Classic Downy Airbed offers retailers and consumers the best value for their money at an opening price point.



AIRBED ONLY		Approximate Inflated Size	Case Pack	Case Weight
68950 / E	Cot Size	30" x 75" x 8¾" 76cm x 1.91m x 22cm	6 ea	31.2 lb (14.2 kg)
68757 / E	Twin	39" x 75" x 8¾" 99cm x 1.91m x 22cm	4 ea	26.2 lb (11.9 kg)
68758 / E	Full	54" x 75" x 8¾" 1.37m x 1.91m x 22cm	3 ea	25.9 lb (11.8 kg)
68759 / E	Queen	60" x 80" x 8¾" 1.52m x 2.03m x 22cm	3 ea	30.6 lb (13.9 kg)
68755 / E	King	72" x 80" x 8¾" 1.83m x 2.03m x 22cm	2 ea	23.9 lb (10.9 kg)

**AIRBED SET
INCLUDES TWO I-BEAM PILLOWS
17" x 11" x 3½" (43cm x 28cm x 9cm)
and a #68612 Double-Quick air pump**

		Approximate Inflated Size	Hand Pump	Case Pack	Case Weight
68765 / E	Queen	60" x 80" x 8¾" 1.52m x 2.03m x 22cm	68612	3 ea	34.4 lb (15.7 kg)



SHELF BOX



FOLDS COMPACTLY

PLUSH FLOCKED TOP FOR COMFORT

- 2-in-1 valve has extra-wide openings for fast inflating and deflating
- Conventional mattress sizes (L x W) for more sleeping area and a better fit for sheets
- 8¾" (22cm) mattress thickness for extra soft comfort

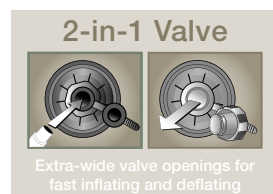

2-in-1 Valve

Extra-wide valve openings for fast inflating and deflating

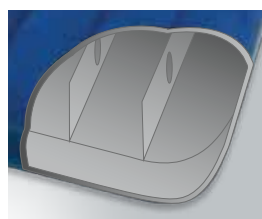

Wave Beam Construction



Airbed Set (#68765/E)

INFLATING TIMES*	
QUEEN	5 Minutes

*INFLATING TIME VARIES BY MATTRESS SIZE AND DESIRED FIRMNESS

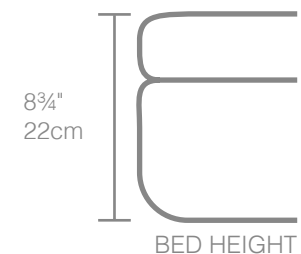

BED HEIGHT

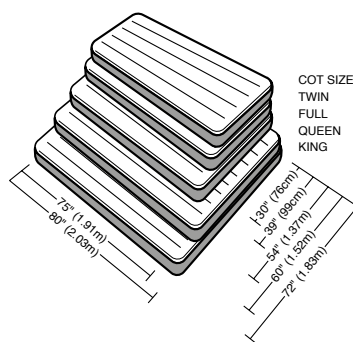

COT SIZE
TWIN
FULL
QUEEN
KING

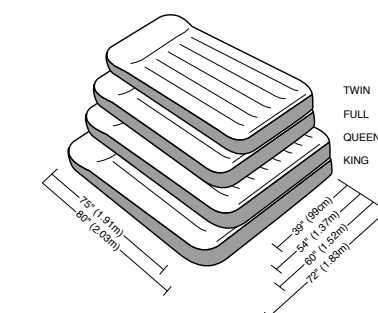

TWIN
FULL
QUEEN
KING

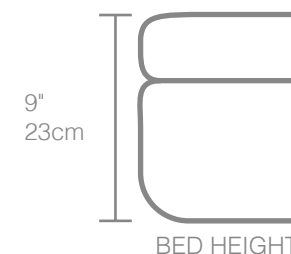

BED HEIGHT

BUILT-IN COMFORT

- Flocked sleeping surface for extra comfort
- A built-in pillow provides bed-like comfort
- Mattress is raised 9" (23cm) from the floor for convenience
- 3-in-1 valve on "Airbed Only" series has extra-wide openings
- Inflated dimensions fit standard sheet sizes



CARRY BAG



SHELF BOX



FOLDS COMPACTLY



BUILT IN AIR PUMP

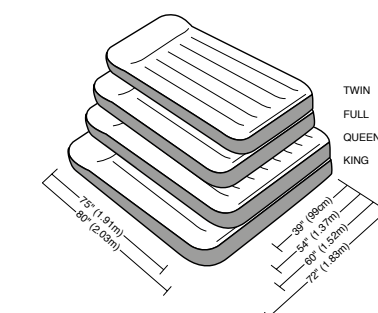

9"
23cm

BED HEIGHT

AIRBED ONLY		Approximate Inflated Size	Case Pack	Case Weight
66767 / E	Twin	39" x 75" x 9" 99cm x 1.91m x 23cm	4 ea	29.9 lb (13.6 kg)
66768 / E	Full	54" x 75" x 9" 1.37m x 1.91m x 23cm	3 ea	29.9 lb (13.6 kg)
66769 / E	Queen	60" x 80" x 9" 1.52m x 2.03m x 23cm	3 ea	35.2 lb (16.0 kg)
66770 / E	King	72" x 80" x 9" 1.83m x 2.03m x 23cm	2 ea	27.9 lb (12.7 kg)

WITH BUILT-IN ELECTRIC PUMP

		Approximate Inflated Size	Built-in Pump	Case Pack	Case Weight
66775E 66779	Twin	39" x 75" x 9" 99cm x 1.91m x 23cm	110 - 120V 220 - 240V	4 ea	38.4 lb (17.5 kg)
66776E 66780	Full	54" x 75" x 9" 1.37m x 1.91m x 23cm	110 - 120V 220 - 240V	3 ea	36.2 lb (16.5 kg)
66777E 66781	Queen	60" x 80" x 9" 1.52m x 2.03m x 23cm	110 - 120V 220 - 240V	3 ea	42.1 lb (19.2 kg)

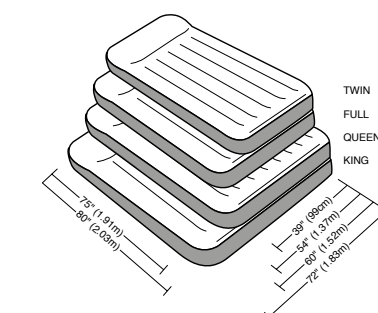

9"
23cm

BED HEIGHT

For those who need a pillow but lack the space to carry one, this luxurious flocked bed is the answer. The waterproof and stain resistant surface makes it easy to keep clean while providing the soft comfort of home.



AC Electric Pump INFLATING TIMES*	
TWIN	1 Minute
FULL	1½ Minutes
QUEEN	1¾ Minutes

*INFLATING TIME VARIES BY MATTRESS SIZE AND DESIRED FIRMNESS



Wave Beam Construction



Built-in AC Electric Pump



Built-in pillow for added convenience

CAMPING MATS

A quick, simple and lightweight sleeping solution while camping. Wave beam construction provides a supportive sleeping surface ideal for the outdoors. Includes a soft top and laminate bottom for added comfort and durability for great sleep anywhere you go. Your next great outdoor adventure awaits...



CAMPING MAT	Approximate Inflated Size	Case Pack	Case Weight
NEW 67997 / E	26½" x 72½" x 6¾" 67cm x 1.84m x 17cm	6 ea	22.4 lb (10.2 kg)
NEW 67998 / E	28½" x 74½" x 8" 72cm x 1.89m x 20cm	6 ea	29.0 lb (13.2 kg)
NEW 67999 / E	50" x 76" x 9½" 1.27m x 1.93m x 24cm	3 ea	24.5 lb (11.1 kg)

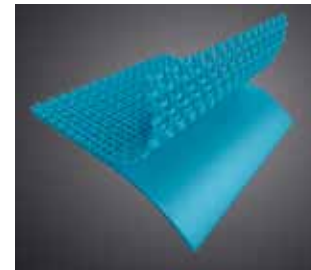

Puncture-resistant
2-ply laminate

PLUSH TOP WITH LAMINATED BOTTOM FOR COMFORT AND DURABILITY

- Velvety sleeping surface for extra comfort
- Each mat has a unique construction that helps provide more comfort to campers
- 2-ply laminate bottom provides extra durability for the outdoors



SHELF BOX FOLDS COMPACTLY

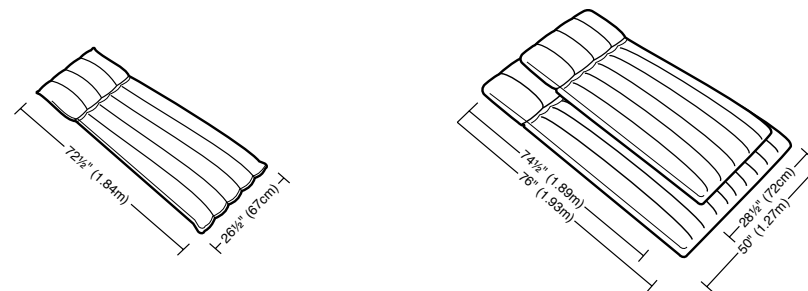

COT SIZE CAMPING MAT

Find your perfect sleep solution for the outdoors with the Cot Size Camping Mat. Made with rugged laminated PVC, this mat is designed to fit easily on cots or inside tents. This lightweight and portable mat provides a smooth and comfortable sleeping surface in any outdoor environment.

CAMPING MAT	Approximate Inflated Size	Case Pack	Case Weight
68708 / E Cot Size	30" x 72" x 4" (76cm x 1.83m x 10cm)	6 ea	27.5 lb (12.5 kg)

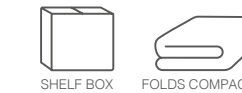

SHELF BOX FOLDS COMPACTLY

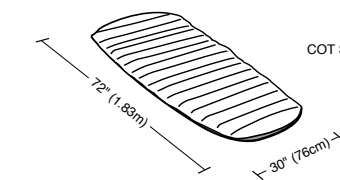

SUPER-TOUGH™ AIRBED

Bright, bold and compact, the Super-Tough™ airbed provides campers with the ultimate camping experience.

The Super-Tough™ PVC and polyester laminate create a smooth, yet strong sleeping surface, guaranteed to give campers a great night's sleep. High-strength Fiber-Tech™ fibers make up the inner construction and are combined with a puncture resistant laminated surface to make this camping airbed very strong, comfortable, and long-lasting.

For the ultimate in convenience, the Super-Tough™ bed is also available with a built-in 6 C-cell battery pump.



WITH BUILT-IN 6 C-CELL BATTERY PUMP		Approximate Inflated Size	Case Pack	Case Weight
64791 / E	Twin	39" x 75" x 8" 99cm x 1.91m x 20cm	3 ea	24.6 lb (11.2 kg)

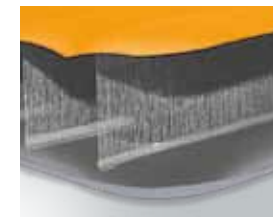

Fiber-Tech™ Technology



Perfect for camping with 6 C-cell batteries (not included)

STRENGTH, LIGHTWEIGHT, CONVENIENCE & COMFORT

- Fiber-Tech™ interior construction
- Bright and bold outdoor color
- Super-Tough™ laminated exterior surfaces



CARRY BAG



SHELF BOX



FOLDS COMPACTLY

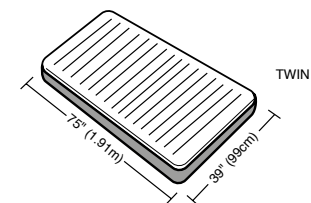

TWIN

ROLL 'N GO™ AIRBED

The Roll 'N Go™ Airbed offers the perfect ultra light weight sleep solution for your next camping trip.

WITH HAND PUMP	Approximate Inflated Size	Hand Pump	Case Pack	Case Weight
64780 / E Cot Size	30" x 75" x 5" 76cm x 1.91m x 13cm	68612	4 ea	20.9 lb (9.5 kg)

ULTIMATE OUTDOOR BED WITH PUMP

- Fiber-Tech™ interior construction
- Eco-friendly TPU laminated fabric – phthalate-free material
- Hand-held high output lightweight manual air pump
- Duffel bag with handle included



SHELF BOX



FOLDS COMPACTLY

This PVC Free airbed is constructed of laminated TPU, which means it is:

- Super Tough – Softens up the rough outdoors with a very durable, eco-friendly material
- Strong Support System – Inflates up to three times the pressure of a regular PVC junior-twin airbed for a firmer sleeping surface
- Ultra Lightweight – Weighs approximately one fourth less than a common junior-twin PVC constructed airbed



MAXIMUM DURABILITY

The strong TPU (Thermoplastic Polyurethane) laminated material and innovative Fiber-Tech™ inner construction transform the toughest ground into a refreshing night's sleep. It retains elasticity in temperature as low as -4° F/-20° C.

Made of TPU – A PVC-free eco-friendly material

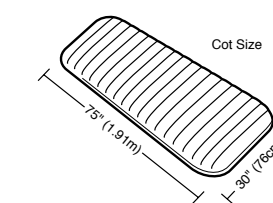

Cot Size



Fiber-Tech™ Technology



Hand Pump (#68612)

AIR FURNITURE

Style. Color. Fun.
Cool Living Spaces with Intex.

Intex brings to you an exciting and vibrant line of air furniture for any age, any setting and any season! With great colors and design, whether for the indoors or the outdoors, Intex has something for everyone.

Decorate your room with Intex!



BEANLESS BAG™ CHAIR ASSORTMENT

A great bean bag without the hassle of bean bag inserts and slipcovers. Just unfold and inflate, and in minutes you have a super soft bean bag that is perfect for lounging, studying, or watching movies. Vivid colors will brighten up any room. Comes in an assortment of three bright and vivid colors: Magenta Pink, Lime Green, or Lilac Purple.



PERFECTLY PORTABLE BEANLESS BAG™

- Available in magenta pink, lime green and lilac purple
- Folds compactly for storage
- Shelf box

ITEM	Approximate Inflated Size	Case Pack	Case Weight
68569NP / EP	42" x 41" x 27" 1.07m x 1.04m x 69cm	6 ea, asst	33.6 lb (15.3 kg)



U.S. Patent No. 6,152,530

MODE CHAIR

Modern and effortlessly cool, our Mode Chair is a surefire way to turn your pad into the stylishly chic place it deserves to be. It's the best place to kick back or use as edgy party decor. The innovative design comes in several colors to fit your unique style including Magenta Pink, Lime Green, and White. Not only will the colors support your style but the comfortable structure will support you, in style.



Indoor Use

FOR EXTENDED SEATING

- Supportive back
- Textured seat for additional softness and contoured fit
- Matte finish
- Repair patch
- Shelf box

ITEM	Approximate Inflated Size	Color	Case Pack	Case Weight
68591NP / EP	33" x 39" x 30" 84cm x 99cm x 76cm	White	6 ea	29.2 lb (13.3 kg)
68592NP / EP	33" x 39" x 30" 84cm x 99cm x 76cm	3 Colors	6 ea, asst	29.2 lb (13.3 kg)



CAFÉ CHAISE CHAIR

Stunning and eye-catching, this Café Chaise Chair adds a splash of color and flair to any room! Paired with an ottoman, the advanced structural design provides an exceptionally comfortable seat regardless of your height. The chair inflates quickly and can be deflated easily when more space is needed.



Indoor Use

COLORFUL CUSHY LUXURY

- Combo valve has extra-wide openings for fast inflating and deflating
- Available in lilac purple, sky blue, and sunny orange
- Folds compactly for storage
- Shelf box

ITEM	Approximate Inflated Size	Case Pack	Case Weight
68572NP / EP Chair	41" x 43" x 28" 1.04m x 1.09m x 71cm	3 ea, asst	20.9 lb (9.5 kg)
Ottoman	25" x 11" 64cm x 28cm		



ULTRA LOUNGE

Attractive contours from any angle, the beauty of this lounge chair is matched only by its comfort. Contact surfaces on the top and sides are lined with flocking for the touch of luxury. The side cup holder is just as indispensable here as in your favorite sports car. The inflatable ottoman provides a great place to rest your feet.



Indoor Use

RELAX AT HOME WITH OUR ULTRA LOUNGE

- 2-in-1 valve has extra-wide openings for fast inflating and deflating
- Convenient cup holder for refreshments
- Folds compactly for storage
- Shelf box

ITEM		Approximate Inflated Size	Case Pack	Case Weight
68564NP / EP	Chair	39" x 51" x 30" 99cm x 1.30m x 76cm	4 ea	31.5 lb (14.3 kg)
	Ottoman	25" x 11" 64cm x 28cm		



Comfortable seating with side cup holder

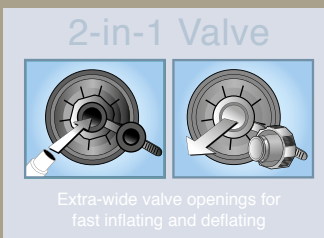

2-in-1 Valve

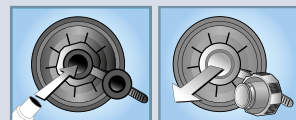

Extra-wide valve openings for fast inflating and deflating



BEANLESS BAG™ CHAIR

Intex completes the Beanless Bag™ Chair line with the introduction of a warm, neutral color combined with our revolutionary corduroy texture flocking! Its elegant and luxurious look and feel will add a new dimension to any room!



Indoor Use

PERFECTLY PORTABLE BEANLESS BAG™

- Folds compactly for storage
- Shelf box

ITEM	Approximate Inflated Size	Case Pack	Case Weight
68579NP / EP	42" x 41" x 27" 1.07m x 1.04m x 69cm	6 ea	34.3 lb (15.6 kg)

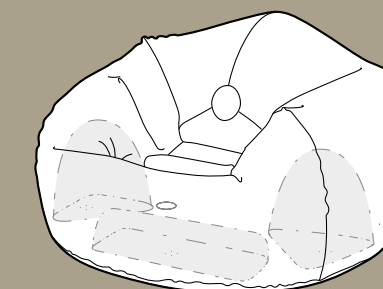

Beanless Bag™ chair inner structure
U.S. Patent No. 6,152,530

PULL-OUT CHAIR

Built for versatility, the Intex Pull-Out Chair is designed for relaxing just about anywhere, whether you are camping or at home. Watch TV, read a book, or just relax in the soft flocced chair and then pull out the cushion into a twin size air mattress when you are ready to go to sleep. Inflates and is ready to go in minutes!



STURDY COMFORT

- 2-in-1 valve has extra-wide openings for fast inflating and deflating
- Folds compactly for storage
- Cup holder for refreshments
- Shelf box

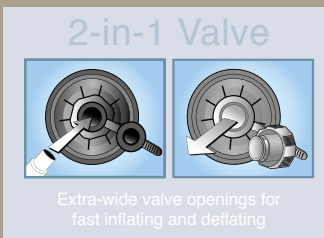

ITEM	Approximate Inflated Size	Case Pack	Case Weight
68565NP / EP	42" x 87" x 26" 1.07m x 2.21m x 66cm	2 ea	22.3 lb (10.1 kg)



PULL-OUT SOFA

A versatile sofa that offers an affordable and comfortable sleeping solution for any home. Quick and easy to inflate, this sofa conveniently pulls out into a Queen-size bed that sleeps two people. Its portability makes it ideal to take on the road. The soft flocced surface provides added comfort, perfect for sitting or sleeping.



PRACTICAL & VERSATILE

- 2-in-1 valve has extra-wide openings for fast inflating and deflating
- 3 quick inflation and deflation valves
- Comfortable backrest and armrest
- Folds compactly for storage
- Two cup holders
- Shelf box

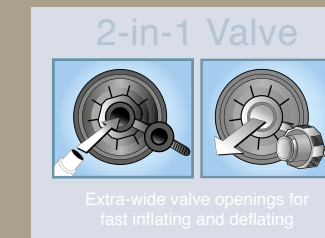

ITEM	Approximate Inflated Size	Case Pack	Case Weight
68566NP / EP	76" x 87" x 26" 1.93m x 2.21m x 66cm	2 ea	41.1 lb (18.7 kg)



BEANLESS BAG™ CLUB CHAIR

Relax in style and comfort with our new Beanless Bag™ Club Chair. The luscious flocking in soothing olive green color offers a sophisticated appeal - making it a perfect addition to any room!

NEW



Indoor Use

PERFECTLY PORTABLE BEANLESS BAG™

- Combo valve has extra-wide openings for fast inflating and deflating
- Folds compactly for storage
- Shelf box

ITEM	Approximate Inflated Size	Case Pack	Case Weight
68576NP / EP	49" x 47" x 30" 1.24m x 1.19m x 76cm	3 ea	24.9 lb (11.3 kg)



U.S. Patent No. 6,152,530



EMPIRE CHAIR

Modern, sophisticated and endlessly comfortable best describes this new addition to our line of inflatable chairs. In sunny orange, pink or lime green with an innovative transparent trim, this chair is the perfect combination of form and function. It's ideal for teens, college students and young professionals!



Outdoor & Indoor Use

AN INVITING SPLASH OF COLOR AND COMFORT

- Extra strong laminated bottom for better durability
- Great for both indoors and outdoors
- Puncture-resistant 2-ply reinforced laminated bottom
- Additional chamber fills with water to anchor chair
- Shelf box

ITEM	Approximate Inflated Size	Color	Case Pack	Case Weight
68581NP / EP	44" x 43" x 27" 1.12m x 1.09m x 69cm	Green	3 ea	21.7 lb (9.9 kg)
68582NP / EP	44" x 43" x 27" 1.12m x 1.09m x 69cm	3 Colors	3 ea, asst	21.7 lb (9.9 kg)



MEGA LOUNGE

What makes this a mega lounge? Keeping multi-function in mind while covered in plush flocking, this lounge is designed for the ultimate comfort experience. Its long seat will let you sprawl out when you are gaming or watching TV. The included cup holder lets you keep snacks or a drink at arm's length.

NEW



PERFECT FOR RELAXING AT HOME

- Velvet flocked finish
- Grooved and contoured shape for a natural fit and added comfort
- Long seat perfect for extending legs
- 1 cup holder
- 2-in-1 valve with extra wide openings for fast inflation and deflation
- Puncture-resistant 2-ply reinforced laminated bottom
- Additional chamber fills with water to anchor lounge
- Repair patch
- Shelf box

ITEM	Approximate Inflated Size	Case Pack	Case Weight
68595NP / EP	34" x 67" x 37" 86cm x 1.70m x 94cm	3 ea	27.1 lb (12.3 kg)

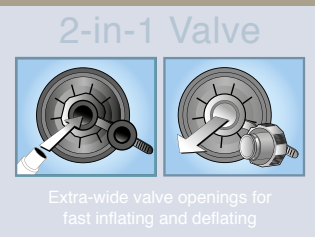

SPLASH LOUNGE

Lounge away your day with the Intex Splash Lounge! Its soft flocked surface and stylish blue and white colors will look gorgeous indoors or outdoors. Perfect for gaming, lounging or relaxing, it makes a great casual addition to any room. The reinforced bottom also makes it durable for lounging on the patio, yard or poolside.



PERFECTLY PORTABLE LOUNGE

- Extra strong laminated bottom for better durability
- Great for both indoors and outdoors
- Puncture-resistant 2-ply reinforced laminated bottom
- Additional chamber fills with water to anchor lounge
- Shelf box

ITEM	Approximate Inflated Size	Case Pack	Case Weight
68880NP / EP	33" x 67" x 32" 84cm x 1.70m x 81cm	3 ea	21.5 lb (9.8 kg)



Soft Flocked Surface



ULTRA DAYBED LOUNGE

The Ultra Daybed Lounge invites you to relax, soak up the sun and hang out with friends. It's an elegant addition to any room, patio or yard as the reinforced bottom and soft flocking make it versatile enough for both indoors and outdoors.



RELAX AT HOME WITH OUR ULTRA DAYBED LOUNGE

- Backrest for extra comfort
- Extra strong laminated bottom for better durability
- Great for both indoors and outdoors
- Puncture-resistant 2-ply reinforced laminated bottom
- Additional chamber fills with water to anchor lounge
- Shelf box

ITEM	Approximate Inflated Size	Case Pack	Case Weight
68881NP / EP	75" (D) x 20" (H) 1.91m x 51cm	2 ea	29.5 lb (13.4 kg)

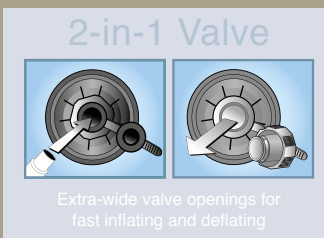

CORNER SOFA

A corner sofa can be a fantastic addition to any living room. This beautifully designed piece is luxurious yet convenient. Create an intimate conversation area or an expansive seating arrangement for family and friends. Casual and comfortable, this sofa is designed with deep seats and wide armrests, and sleekly streamlined for sophisticated appeal.



SPACIOUS COMFORT AND CONVENIENCE

- Quality-tested, waterproof-flocked surface for a luxurious feel
- 2-in-1 valve with extra-wide openings for fast inflating and deflating
- Neutral color to suit any home decor
- Repair patch
- Shelf box

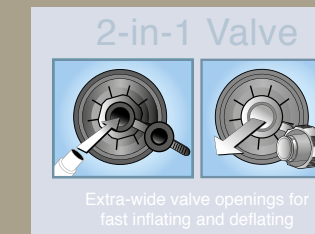

ITEM	Approximate Inflated Size	Case Pack	Case Weight
68575NP / EP	101" x 80" x 30" 2.57m x 2.03m x 76cm	1 ea	28.6 lb (13.0 kg)



COZY KIDZ™ AIRBED

The perfect airbed for kids with soft, inflatable pillows in three fun and exciting colors! It will come in handy for sleepovers, nap time and travel, without sacrificing comfort or convenience!



COZY & FUN

- Assorted bright, fun colors
- Soft flocking for extra comfort
- Includes inflatable, flocked pillow
- Repair patch
- Shelf box

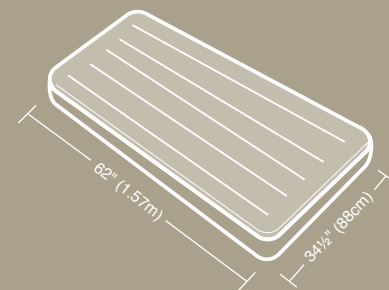

ITEM	Approximate Inflated Size	Case Pack	Case Weight
66801NP / EP	34½" x 62" x 7" 88cm x 1.57m x 18cm	6 ea, asst	27.0 lb (12.3 kg)



KIDZ TRAVEL BED SET

Excellent solution to sleep comfortably when away from home. Perfect for trips, sleepovers, camping and even for nap times!



QUICK & EASY SOLUTION

- Includes hand pump
- Inner mattress size: 28" x 52" x 4" (71cm x 1.32m x 10cm)
- Uses standard crib sheets
- Inflates and deflates quickly
- Includes carry bag
- Shelf box



Sleep area is
28" x 52" (71cm x 1.32m)
with soft frame surround

ITEM	Approximate Inflated Size	Hand Pump	Case Pack	Case Weight
66810NP / EP	42" x 66" x 10" 1.07m x 1.68m x 25cm	68612	3 ea	29.0 lb (13.2 kg)



ACCESSORIES

PILLOWS



#68672 / E Downy Pillow

- 17" x 11" x 3½" (43cm x 28cm x 9cm)
- I-beam construction
- Pegable box
- 24 ea, 8.4 lb (3.8 kg)



#68675 / E Travel Pillow

- 14" x 12" x 4" (36cm x 30cm x 10cm)
- Black super soft flopped surface
- Perfect for those long plane and car trips
- Contoured for neck support
- Folds up for easy travel
- Pegable box
- 36 ea, 8.3 lb (3.8 kg)



#68676NP / EP Kidz Pillows

- 17" x 11" x 3½" (43cm x 28cm x 9cm)
- Available in Sunny Orange, Sky Blue and Lime Green
- Pegable box
- 24 ea, asst 8.4 lb (3.8 kg)



ACCESSORIES

AIRBED COVER

Add a layer of comfort to your airbed with our Intex fitted polyester bed covers. The all-new fitted bed covers adds a touch of home for your guests or your next outdoor adventure. Bed covers comes in both Twin and Queen sizes. Ideal for mid-rise to double high beds.



#69641 / E AIRBED COVER

- Fits twin size airbed up to 18" (46cm) high
- Elegant quilted pattern
- 100% Polyester
- 200 thread count
- 75D x 75D x 200T
- 39" W x 75" L x 4" H (99cm x 1.91m x 10cm)
- 3 ea, 4.8 lb (2.2 kg)

#69643 / E AIRBED COVER

- Fits queen size airbed up to 22" (56cm) high
- Elegant quilted pattern
- 100% Polyester
- 200 thread count
- 75D x 75D x 200T
- 60" W x 80" L x 4" H (1.52m x 2.03m x 10cm)
- 3 ea, 6.7 lb (3.1 kg)



#69643



#69641

ACCESSORIES

MANUAL PUMPS

#69613 / E Double Quick Mini Hand Pump

- 11½" (29cm)
 - TUV RL approved
 - Inflates on fore and back strokes
- 24 ea, 7.5 lb (3.4 kg)



#69611 / E Bellows Foot Pump

- 11" (28cm)
 - TUV RL approved
 - Inflates and deflates
 - Shrink-wrapped with litho label
- 6 ea, 8.4 lb (3.8 kg)



#68610 / E Giant Bellows Foot Pump

- 50% more air flow than of #69611
 - 12" (30cm)
 - TUV RL approved
 - Inflates and deflates
 - Shelf box
- 6 ea, 13.6 lb (6.2 kg)



#68612 / E Double Quick I Hand Pump

- 11½" (29cm)
 - 3 interconnecting nozzles with hose
 - TUV RL approved
 - Inflates on both up and down strokes
 - Shelf box
- 12 ea, 11.1 lb (5.0 kg)



#68614 / E Double Quick II Hand Pump

- 2 times the air flow of #68612
 - 14" (36cm)
 - 3 interconnecting nozzles with hose
 - TUV RL approved
 - Inflates on both up and down strokes
 - Shelf box
- 4 ea, 6.1 lb (2.8 kg)



#68605 / E Double Quick III S Hand Pump

- 3 times the air flow of #68612
 - 14½" (37cm)
 - 3 interconnecting nozzles with hoses
 - TUV RL approved
 - Inflates and deflates
 - Pumps on up and down strokes
 - Shelf box
- 3 ea, 6.5 lb (3.0 kg)



#68615 / E Double Quick III Hand Pump

- 3½ times the air flow of #68612
 - 19" (48cm)
 - TUV RL approved
 - Large nozzle threaded for athletic ball inflating needle (one included)
 - Inflates athletic balls up to 8 psi
 - Inflates and deflates
 - Pumps on up and down strokes
 - Shelf box
- 3 ea, 9.0 lb (4.1 kg)



U.S. Patent
No. 6,299,420



ACCESSORIES

ELECTRIC PUMPS

Quick-Fill™ AC/DC Electric Pump features include:

- 3 interconnecting nozzles
- 12V DC & AC power adapter for easy Outdoor and Indoor use
- ETL approved (110-120V)
- CE approved (220-240V)
- Shelf box



#66631 (110-120V)
#66632 (220-240V)



Quick-Fill™ DC Electric Pump features include:

- 3 interconnecting nozzles
- Plug into 12V DC automobile cigarette lighter or 12V DC accessory outlet
- ETL approved
- GS, CE approved
- Shelf box



#66626 (12V)



Quick-Fill™ AC Electric Pump features include:

- 3 interconnecting nozzles
- Thermo protector incorporated for safety
- ETL approved (110-120V)
- GS, CE approved (220-240V)
- Shelf box



#66619 (110-120V)
#66620 (220-240V)



Quick-Fill™ High PSI Indoor/outdoor Electric Pump features include:

- 3 interconnecting nozzles with hose
- For both indoor and outdoor use - plugs into cigarette lighter or household electrical outlet
- 2-speed switch
- Inflates athletic balls up to 12 psi
- Detachable DC cigarette cord
- ETL approved (110-120V)
- GS, CE approved (220-240V)
- Shelf box



#68608 (110-120V)
#68609 (220-240V)



#68638

Quick-Fill™ Battery Pump features include:

- 24% more air flow than previous version (#68639)
- Operates on 6 C-cell size batteries
- 3 interconnecting nozzles
- CE approved
- Shelf box



Quick-Fill™ Rechargeable Pump features include:

- 3 interconnecting nozzles
- A 12V DC power adapter for vehicle charging and a household AC power adapter for home charging
- 12V DC to inflate and deflate while recharging
- Automatic over-charge cut off for safety protection
- New shape with easy carry handle
- ETL approved (110-120V)
- CE approved (220-240V)
- Shelf box



#66621 (110-120V)
#66622 (220-240V)



Quick-Fill™ AC Electric Pump features include:

- 3 interconnecting nozzles with hose
- Thermo protector incorporated for safety
- New shape with easy carry handle
- ETL approved (110-120V model)
- GS, CE approved (220-240V model)
- Shelf box



#66623 (110-120V)
#66624 (220-240V)

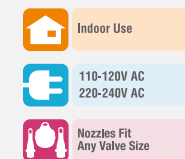

Item #	Voltage			Disposable Batteries	Outdoor Use	Accordion Hose with 3 Nozzles	3 Interconnecting Nozzles	Max. Air Flow (L/min)	Case Pack	Weight lb (kg)
	110-120 AC	220-240 AC	12 DC							
66631E	•		•		•		•	≥450 (15.9CFM)	6	13.0 (5.9)
66632		•	•		•		•	≥450 (15.9CFM)	6	13.1 (6.0)
66626 / E			•		•		•	≥600 (21.2CFM)	6	8.7 (4.0)
66619E	•				•		•	≥600 (21.2CFM)	6	8.8 (4.0)
66620		•			•		•	≥600 (21.2CFM)	6	8.6 (3.9)
66621E	• (CHARGING ONLY)		•		•		•	≥600 (21.2CFM)	4	10.8 (4.9)
66622		• (CHARGING ONLY)	•		•		•	≥600 (21.2CFM)	4	10.8 (4.9)
66623E	•				•		•	≥1100 (38.9CFM)	4	11.1 (5.1)
66624		•			•		•	≥1100 (38.9CFM)	4	11.1 (5.1)
68608E	•		•		•		•	≥400 (14.1CFM)	4	30.3 (13.8)
68609		•	•		•		•	≥400 (14.1CFM)	4	30.3 (13.8)
68638 / E				6 x C	•		•	≥380 (13.4CFM)	6	6.4 (2.9)



64101 NEW
DURA-BEAM® STANDARD

	Approximate Inflated Size
64101 / E Twin	39" x 75" x 10" 99cm x 1.91m x 25cm
64102 / E Full	54" x 75" x 10" 1.37m x 1.91m x 25cm
64103 / E Queen	60" x 80" x 10" 1.52m x 2.03m x 25cm

P.11

64115 NEW
DURA-BEAM® STANDARD

	Approximate Inflated Size	Built-in Pump
64115E Twin 64116	39" x 75" x 12" 99cm x 1.91m x 30cm	110 - 120V 220 - 240V
64117E Queen 64118	60" x 80" x 12" 1.52m x 2.03m x 30cm	110 - 120V 220 - 240V

P.12

64121
DURA-BEAM® STANDARD

	Approximate Inflated Size	Built-in Pump
64121E Twin 64122	39" x 75" x 16½" 99cm x 1.91m x 42cm	110 - 120V 220 - 240V
64123E Queen 64124	60" x 80" x 16½" 1.52m x 2.03m x 42cm	110 - 120V 220 - 240V

P.13

64769
PREMAIRE®

	Approximate Inflated Size	Built-in Pump
64769E Queen 64770	60" x 80" x 18" 1.52m x 2.03m x 46cm	110 - 120V 220 - 240V

P.36-37

64780

	Approximate Inflated Size	Hand Pump
64780 / E Cot Size	30" x 75" x 5" 76cm x 1.91m x 13cm	68612

P.47

64791

	Approximate Inflated Size
64791 / E Twin	39" x 75" x 8" 99cm x 1.91m x 20cm

P.46

64131
DURA-BEAM® STANDARD

	Approximate Inflated Size	Built-in Pump
64131E Twin 64132	39" x 75" x 16½" 99cm x 1.91m x 42cm	110 - 120V 220 - 240V
64135E Queen 64136	60" x 80" x 16½" 1.52m x 2.03m x 42cm	110 - 120V 220 - 240V

P.14

64139
DURA-BEAM® STANDARD

	Approximate Inflated Size	Built-in Pump
64139E Queen 64140	60" x 80" x 20" 1.52m x 2.03m x 51cm	110 - 120V 220 - 240V

P.15

64411
DURA-BEAM® PLUS

	Approximate Inflated Size	Built-in Pump
64411E Twin 64412	39" x 75" x 18" 99cm x 1.91m x 46cm	110 - 120V 220 - 240V
64413E Queen 64414	60" x 80" x 18" 1.52m x 2.03m x 46cm	110 - 120V 220 - 240V

P.18-19

64901 NEW
PREMAIRE®

	Approximate Inflated Size	Built-in Pump
64901E Twin 64902	39" x 75" x 18" 99cm x 1.91m x 46cm	110 - 120V 220 - 240V
64903E Full 64904	54" x 75" x 18" 1.37m x 1.91m x 46cm	110 - 120V 220 - 240V
64905E Queen 64906	60" x 80" x 18" 1.52m x 2.03m x 46cm	110 - 120V 220 - 240V

P.34

64925 NEW
PREMAIRE®

	Approximate Inflated Size	Built-in Pump
64925E Queen 64926	60" x 80" x 18" 1.52m x 2.03m x 46cm	110 - 120V 220 - 240V

P.35

66767

	Approximate Inflated Size	Built-in Pump
66767 / E Twin 66775E 66779	39" x 75" x 9" 99cm x 1.91m x 23cm	— 110 - 120V 220 - 240V
66768 / E Full 66776E 66780	54" x 75" x 9" 1.37m x 1.91m x 23cm	— 110 - 120V 220 - 240V
66769 / E Queen 66777E 66781	60" x 80" x 9" 1.52m x 2.03m x 23cm	— 110 - 120V 220 - 240V
66770 / E King	72" x 80" x 9" 1.83m x 2.03m x 23cm	—

P.43

66801

	Approximate Inflated Size
66801NP / EP	34½" x 62" x 7" 88cm x 1.57m x 18cm

P.62

66810 NEW color

	Approximate Inflated Size	Hand Pump
66810NP / EP	42" x 66" x 10" 1.07m x 1.68m x 25cm	68612

P.63

66950

	Approximate Inflated Size
66950 / E Cot Size	30" x 75" x 8½" 76cm x 1.91m x 22cm
66927 / E Twin	39" x 75" x 8½" 99cm x 1.91m x 22cm
66928 / E Full	54" x 75" x 8½" 1.37m x 1.91m x 22cm
66929 / E Queen	60" x 80" x 8½" 1.52m x 2.03m x 22cm

P.40

64417
DURA-BEAM® PLUS

	Approximate Inflated Size	Built-in Pump
64417E Queen 64418	60" x 80" x 22" 1.52m x 2.03m x 56cm	110 - 120V 220 - 240V

P.20-21

64443
DURA-BEAM® PLUS

	Approximate Inflated Size	Built-in Pump
64443E Twin 64444	39" x 75" x 20" 99cm x 1.91m x 51cm	110 - 120V 220 - 240V
64445E Queen 64446	60" x 80" x 20" 1.52m x 2.03m x 51cm	110 - 120V 220 - 240V

P.24-25

64455
DURA-BEAM® PLUS

	Approximate Inflated Size	Built-in Pump
64455E Twin 64456	39" x 75" x 18" 99cm x 1.91m x 46cm	110 - 120V 220 - 240V
64457E Queen 64458	60" x 80" x 18" 1.52m x 2.03m x 46cm	110 - 120V 220 - 240V

P.22-23

66967

	Approximate Inflated Size
66967 / E Twin	39" x 75" x 8½" 99cm x 1.91m x 22cm
66968 / E Full	54" x 75" x 8½" 1.37m x 1.91m x 22cm
66969 / E Queen	60" x 80" x 8½" 1.52m x 2.03m x 22cm

P.41

67765
DURA-BEAM® PLUS

	Approximate Inflated Size	Built-in Pump
67765E Twin 67766	39" x 75" x 13" 99cm x 1.91m x 33cm	110 - 120V 220 - 240V
67767E Full 67768	54" x 75" x 13" 1.37m x 1.91m x 33cm	110 - 120V 220 - 240V
67769E Queen 67770	60" x 80" x 13" 1.52m x 2.03m x 33cm	110 - 120V 220 - 240V

P.18-19

67997 NEW

	Approximate Inflated Size
67997 / E	26½" x 72½" x 6½" 67cm x 1.84m x 17cm
67998 / E	28½" x 74½" x 8" 72cm x 1.89m x 20cm
67999 / E	50" x 76" x 9½" 1.27m x 1.93m x 24cm

P.44

64459
DURA-BEAM® PLUS

	Approximate Inflated Size	Built-in Pump
64459E Queen 64460	60" x 90" x 31" 1.52m x 2.29m x 79cm	110 - 120V 220 - 240V

P.30-31

64461
DURA-BEAM® PLUS

	Approximate Inflated Size	Built-in Pump
64461E Twin 64462	39" x 75" x 20" 99cm x 1.91m x 51cm	110 - 120V 220 - 240V
64463E Queen 64464	60" x 80" x 20" 1.52m x 2.03m x 51cm	110 - 120V 220 - 240V

P.26-27

64469 NEW
DURA-BEAM® PLUS

	Approximate Inflated Size	Built-in Pump
64469E Queen 64470	60" x 80" x 20" 1.52m x 2.03m x 51cm	110 - 120V 220 - 240V

P.28-29

68708

	Approximate Inflated Size
68708 / E Cot Size	30" x 72" x 4" 76cm x 1.83m x 10cm

P.45

68950

	Approximate Inflated Size	Hand Pump
68950 / E Cot Size	30" x 75" x 8½" 76cm x 1.91m x 22cm	—
68757 / E Twin	39" x 75" x 8½" 99cm x 1.91m x 22cm	—
68758 / E Full	54" x 75" x 8½" 1.37m x 1.91m x 22cm	—
68759 / E Queen 68765 / E	60" x 80" x 8½" 1.52m x 2.03m x 22cm	— 68612
68755 / E King	72" x 80" x 8½" 1.83m x 2.03m x 22cm	—

P.42